

DON'T WE ALL LOVE THE

DAFRK



PRODUCTS

	12-25	2
A	APOLLO	14
B	B-ZZZ	16
	BRIDGE	20
C	CANNA-2	26
	CHESTER / CHESTER XL	30
	CHUBBY	36
	COPPERFIELD	44
	COUTURE	48
	CROSSLIGHT	52
	CYBE	56
D	d-BEEF	62
	d-CONCRETE	64
	d-COW	66
	d-RABBIT	68
	d-LEATHER	70
	d-SQUEEZE	72
	D2V2	74
F	FRANJE	78
G	GUM	82
H	HEAPS	84
	HERBERT	90
	HOEK	94
	HOPPY	96
	HYPE	100
I	ICE	104
J	JOHN PAWSON LAMP	106
	JUICE	108
K	KNARF	110
	KNIK	112
L	LA CAGE	114
	L-BOW	116
	LGTM-X01	118
	LOOP	122
M	METROPOLIS	124
N	NO COPY	126
	NO FRUIT	128
	NO FRUIT bling bling	132
O	OBLIVION	134
P	PANTY	138
	PAROQ	140
	PAWWW	144
	POC	146
R	ROSET	148
	R&S	150
S	SLITE	152
	SNOWDOME	156
	SON OF EDDY	158
	SPACEWALKER / SPACEWALKER JR.	160
	SPINE	166
	STAR'58	170
	SQUARE ANGEL	172
T	TRAPPED	174
	T&T	176
	TSJOEPY	178
	TWOLVE	180
	YOKOZUNA	182
Z	ZUPER	186

12-25

design Co Twee for Dark



reddot design award
winner 2003



Designpreis der
Bundesrepublik
Deutschland
Nominiert 2004







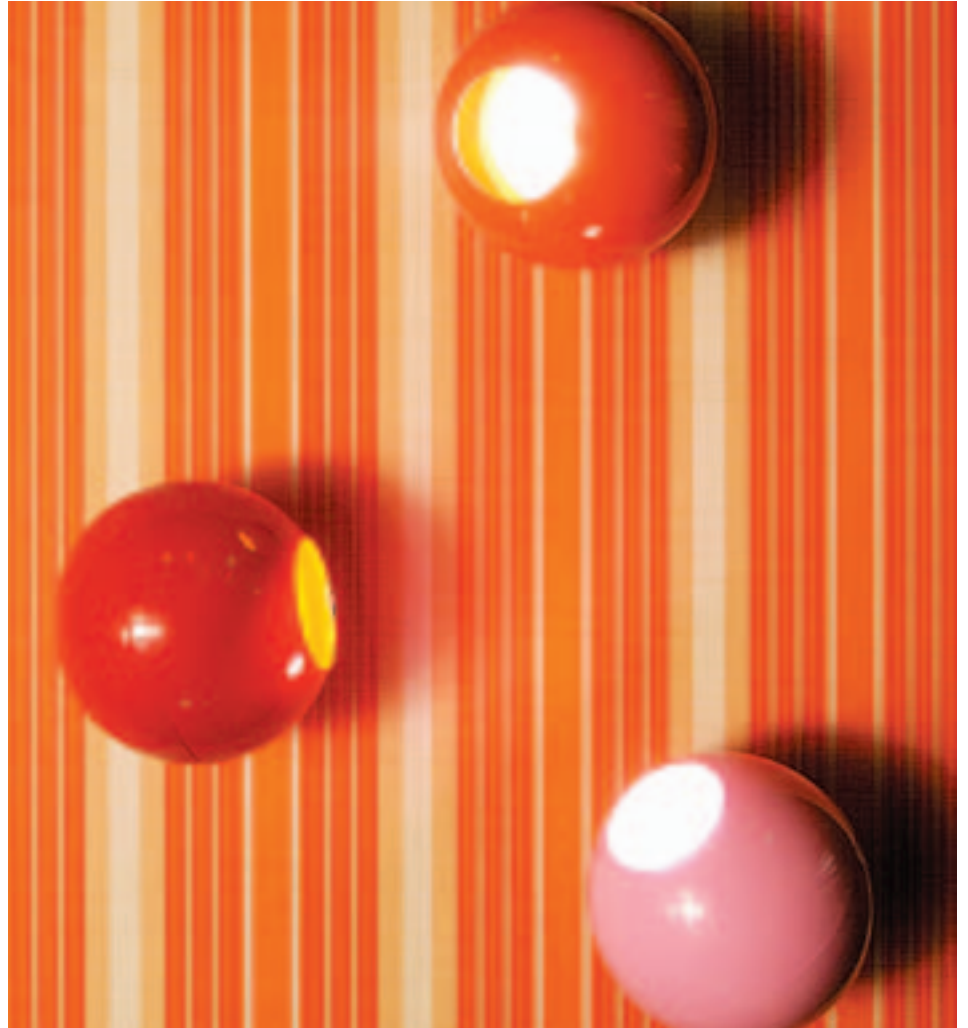

12-25 BASIC with a few possibilities of RAL-colours



12-25 BASIC black glossy



>>>MAGNET + BODY

12-25 BASIC

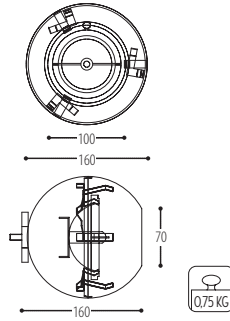

>>>BUILD-IN :
insertbox + magnet + body

12-25

FRONTPLATE CUT OUT 108 x 62 mm

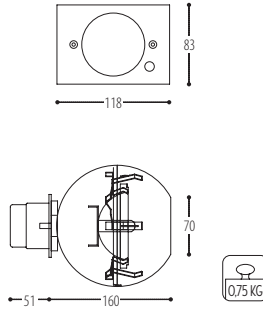

12-25 SET2

FRONTPLATE CUT OUT 180 x 68 mm

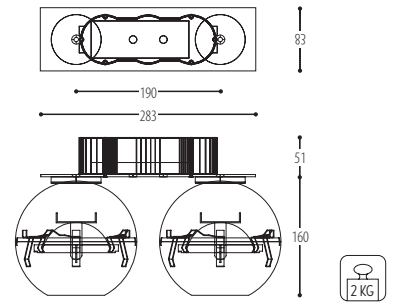

>>>BUILD-UP :
build up box + magnet + body

12-25 0

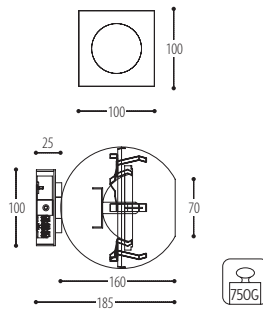

12-25 SET2 0

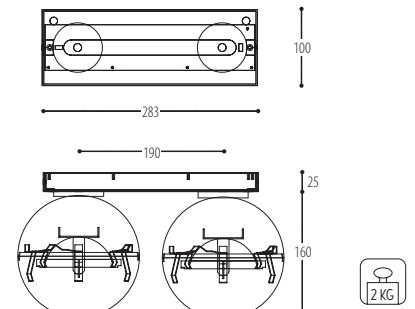

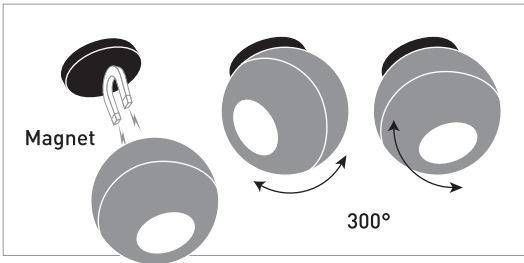

12-25 SET3

FRONTPLATE CUT OUT 180 x 68 mm

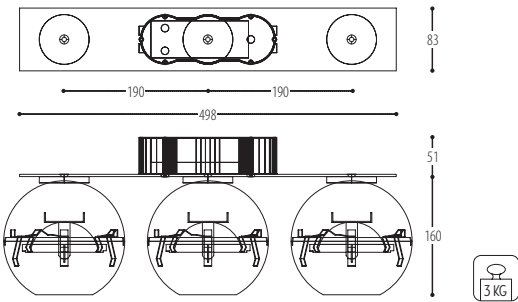

12-25 SET3 O

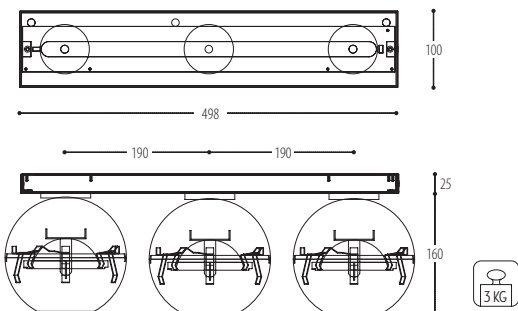

HIR-CE111 35W - 21°
Efficiency factor: 100%

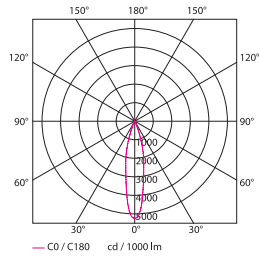

HIR-CE111 35W - 38°
Efficiency factor: 100%

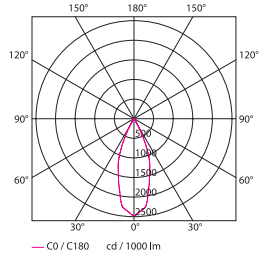

QR-LP111 45W - 22°
Efficiency factor: 100%

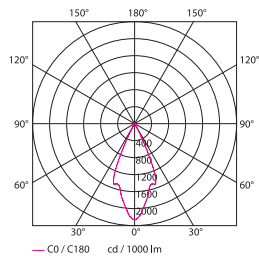

QR-LP111 45W - 45°
Efficiency factor: 100%

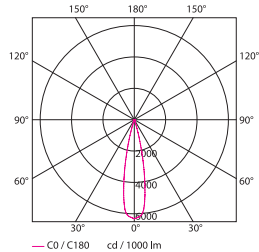

White glossy

Black glossy

Chrome



Metal

12-25 BASIC
12-25 / 12-25 O / 12-25 Set 2 / 12-25 Set 3

		QR-LP111 (MAX 45 W) / G53	
		QPAR20 (MAX 50 W) / E27	
		HIR-CE111 (35 W) / GX8.5	

12-25 Set 2 O / 12-25 Set 3 O

		QR-LP111 (MAX 45 W) / G53	
		QPAR20 (MAX 50 W) / E27	



PROJECT PAGES:

005 - 006 - 028 - 030 - 033 - 040 -
045 - 057 - 078 - 082 - 092 - 093 -
103 - 108 - 148 - 155 - 158 - 159



12-25 FLOOR/PLUG black glossy

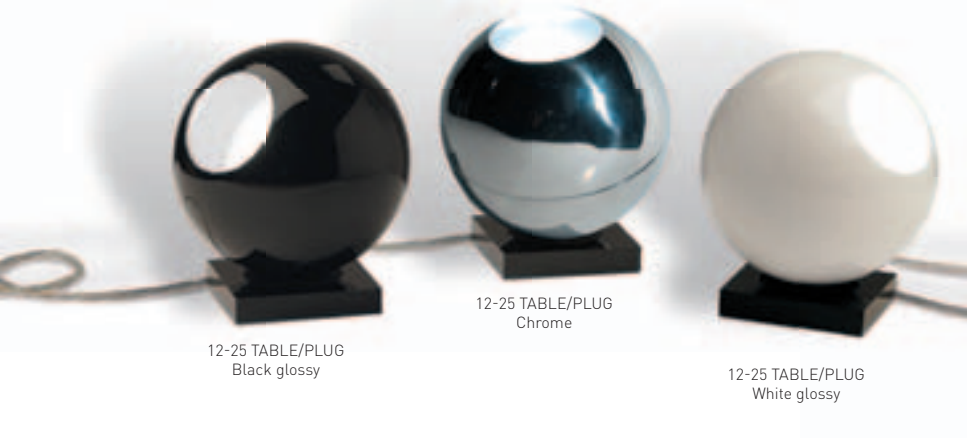

-  White glossy
-  Black glossy
-  Chrome



Metal

12-25 WALL/PLUG

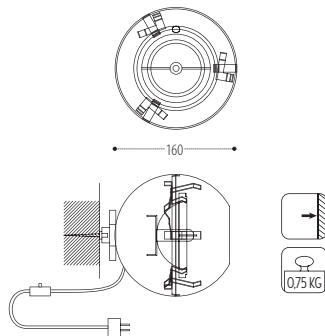

12-25 TABLE/PLUG

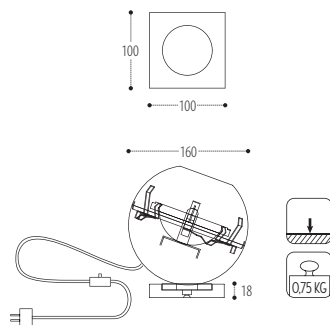

12-25 FLOOR/PLUG

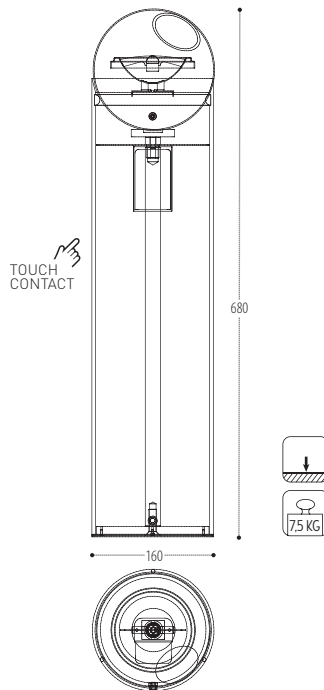

12-25 WALL/PLUG 12-25 TABLE/PLUG

		1x QR-LP111 (MAX 45 W) / G53	INCL TRANSFO
		1x QPAR20 (MAX 50 W) / E27	

12-25 FLOOR/PLUG

		1x QR-LP111 (MAX 45 W) / G53	INCL TRANSFO
---	---	------------------------------	---------------------



PROJECT PAGES:

183



12-25 S white

12-25 S
FRONTPLATE CUT OUT 108 x 62 mm

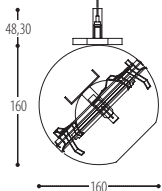
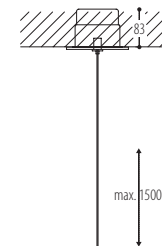
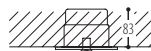
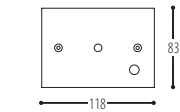

12-25 C

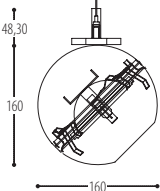
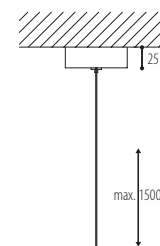
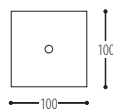

 White glossy

 Black glossy

 Chrome

 On request

 Metal

12-25 S / 12-25 C

		1x QR-LP111 (MAX 45 W) / G53	
		1x QPAR20 (MAX 50 W) / E27	



QR-LP111 45W - 45°

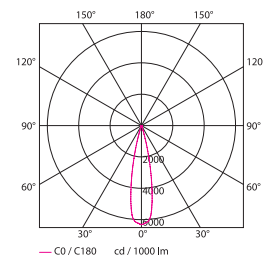

Efficiency factor: 100%

PROJECT PAGES:

006 - 008 - 050 - 124 - 143

APOLLO

design Romy Kühne for Dark



USA 2010



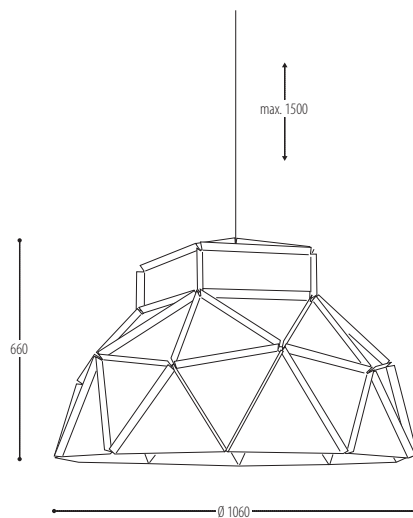
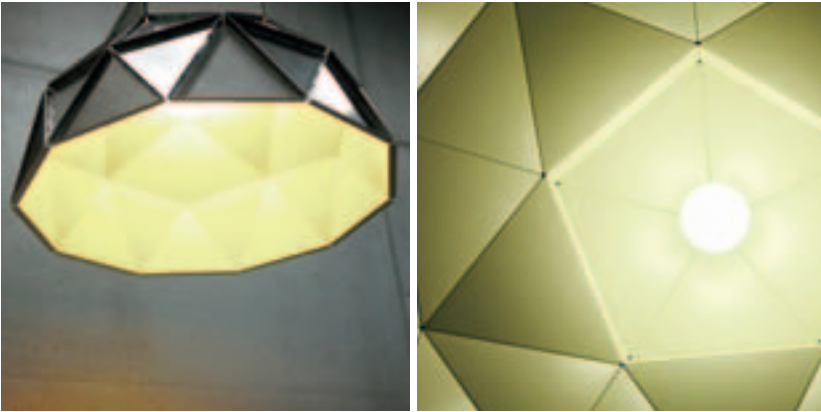

Body Stainless steel / Inside White

Stainless steel

1x G120 (MAX 150 W) / E27

1x TCG-SE (MAX 23 W) / E27

25 KG CE 230 V

0.7m 96° IP20



PROJECT PAGES:
018

B-ZZZ

design Frank Janssens for Dark





B-ZZZ black

B-ZZZ / O

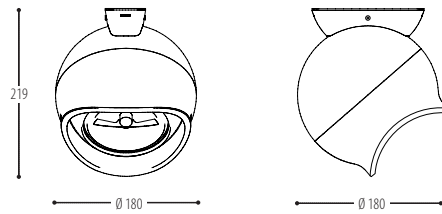

B-ZZZ

CUT OUT Ø 210

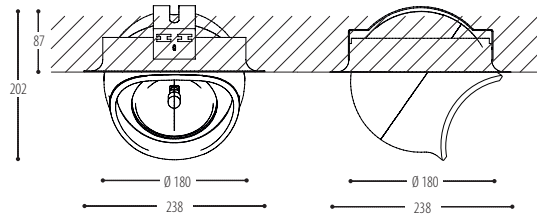

White



Black



On request



QR-LP111 45W-22°

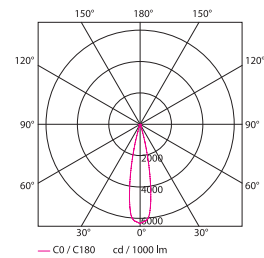

Efficiency factor: 100%

HIR-CE111 35W - 21°

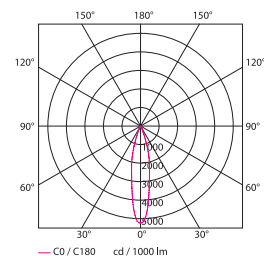

Efficiency factor: 100%

IP20		1x QR-LP111 (MAX 45 W) / G53			
		1x HIR-CE111 (35 W) / GX8,5 1x HIR-CE111 (70 W) / GX8,5 1x HIT-TC-CE (35 W) / G8,5 1x HIT-TC-CE (70 W) / G8,5			
IP66		must be used with 			
		led reflector 			
Colour temp 2700K / 3000K / 4000K --> <table border="1"> <tr> <td>700 Lm</td> <td>>80 CRI</td> <td>700 mA</td> <td>16W</td> </tr> </table>		700 Lm	>80 CRI	700 mA	16W
700 Lm	>80 CRI	700 mA	16W		
Colour temp 2700K / 3000K / 4000K --> <table border="1"> <tr> <td>1000 Lm</td> <td>>80 CRI</td> <td>700 mA</td> <td>23W</td> </tr> </table>		1000 Lm	>80 CRI	700 mA	23W
1000 Lm	>80 CRI	700 mA	23W		
Colour temp 2700K / 3000K / 4000K --> <table border="1"> <tr> <td>700 Lm</td> <td>>95 CRI</td> <td>700 mA</td> <td>23W</td> </tr> </table>		700 Lm	>95 CRI	700 mA	23W
700 Lm	>95 CRI	700 mA	23W		

BRIDGE

design Georges Seris for Dark





BRIDGE WALL fluo blue

BRIDGE TWO mokka



BRIDGE ONE

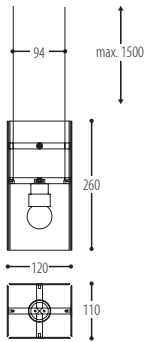

BRIDGE ONE WALL

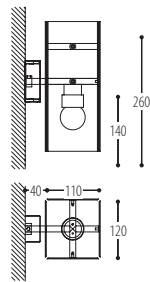

BRIDGE ONE 3P

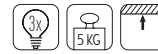
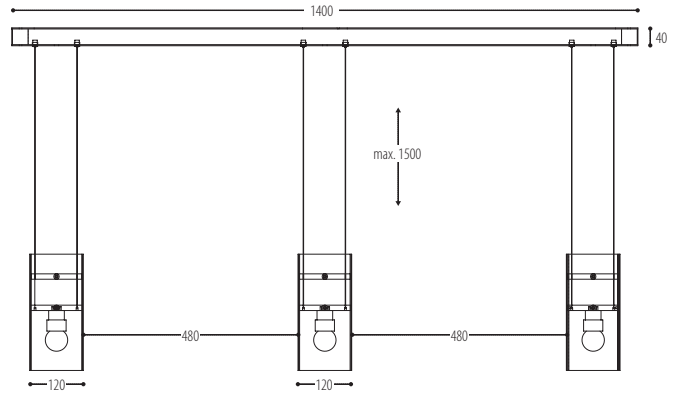

BRIDGE TWO

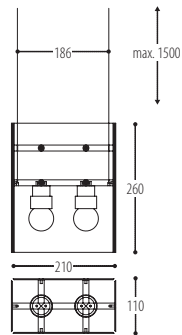

BRIDGE TWO 3P

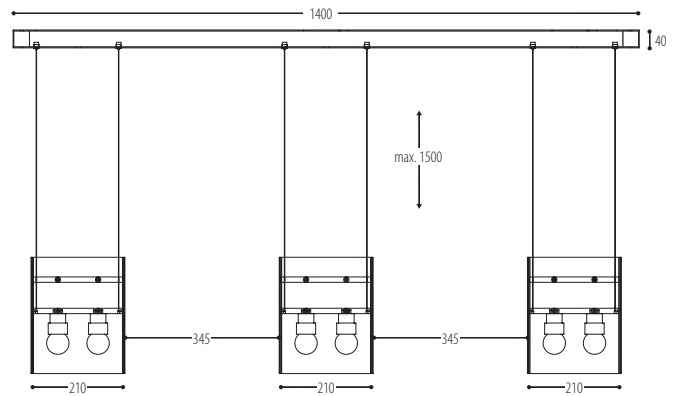



PMMA

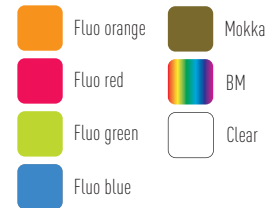

METAL



BRIDGE TWO clear

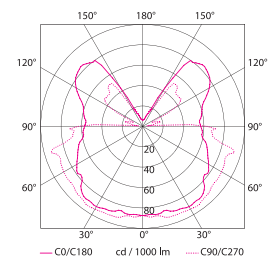

Efficiency factor: 92,32%

PROJECT PAGES:

011 - 020 - 023 - 034 - 036 - 052 - 053 -
 056 - 082 - 095 - 118 - 128 - 129 - 135 -
 136 - 144 - 145 - 152 - 162

CANNA-2

design Frank Janssens for Dark



reddot design award
honourable mention 2009



USA 2008



CANNA-2 / 0
white glossy



CANNA-2 TRACK
black glossy





CANNA-2 black glossy

CANNA-2

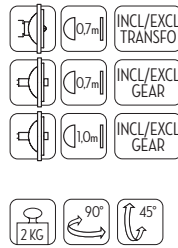
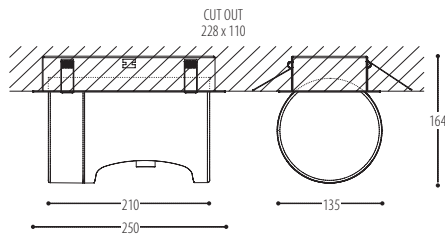

CANNA-2 / O

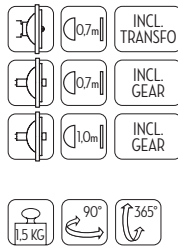
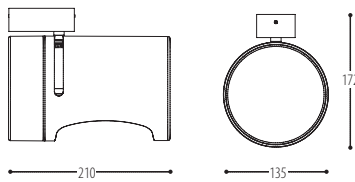

CANNA-2 TRACK

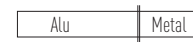
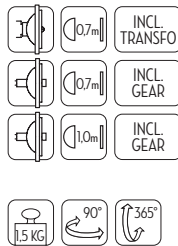
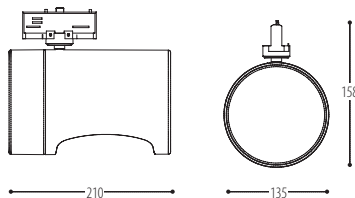

- 1x QR-LP111 (MAX 45 W) / G53
- 1x HIR-CE111 (35 W) / GX8.5
- 1x HIR-CE111 (70 W) / GX8.5



QR-LP111 45W-22°

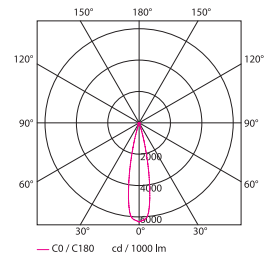

HIR-CE111 35W - 21°

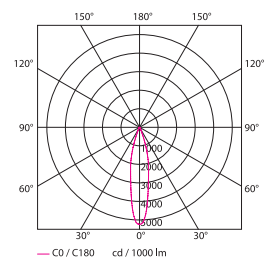

PROJECT PAGES:

044

CHESTER

design Bert & Dennis for Dark





CHESTER S black leather



CHESTER FLOOR white leather



CHESTER
white leather





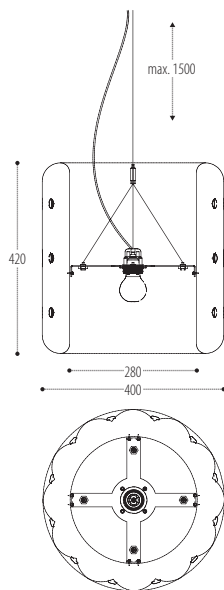

CHESTER
black leather

CHESTER S

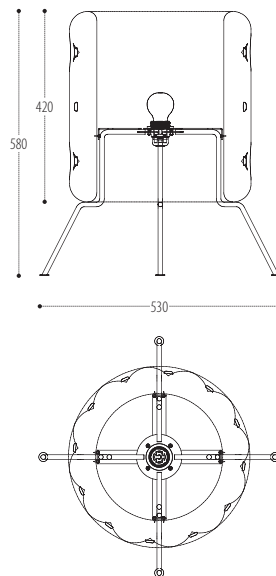

CHESTER FLOOR



-  1x A60 (MAX 60 W) / E27
-  1x OA60 (MAX 42 W) / E27
-  1x TCA-SE (MAX 11 W) / E27
-  1x LED (MAX 7 W) / E27





CHESTER XL white leather

CHESTER XL

TECHNICAL SHEET

35

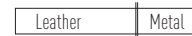
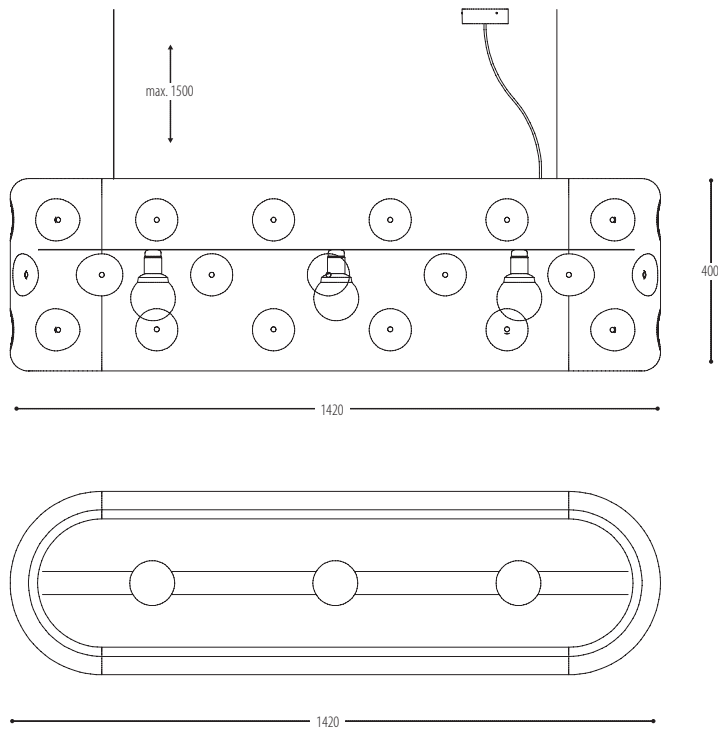

CHUBBY

design Davy Grosemans for Dark



DESIGNPREIS
2009
NOMINIERT



product
design
award
2008 ■



USA 2008



CHUBBY FLOOR - 2xTC-TEL 32W
fabric 12 - down white plexi - up clear

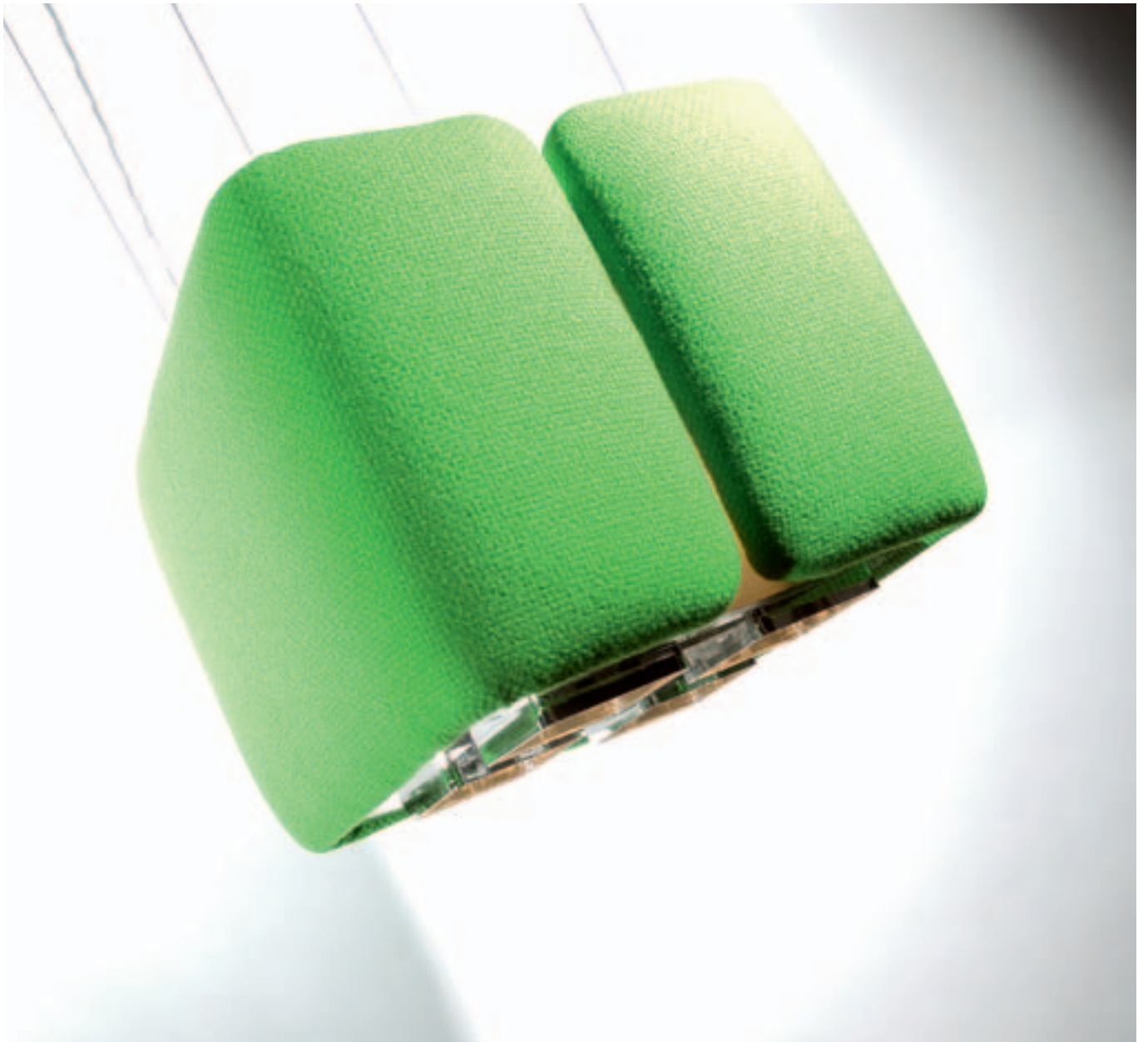

CHUBBY BOX - 2xTC-TEL 32W
fabric 12 - down silver - up clear



CHUBBY

39



CHUBBY S - 2xT16
fabric 01 - down silver louvre BAP 60° - up clear



CHUBBY S - 2xT16 - fabric 07 - down silver - up clear
CHUBBY BOX - 2xTC-TEL 32W - fabric 07 - down silver - up clear



CHUBBY S - 5xQR-LP111 - fabric 03 - down black metal
CHUBBY S - 2xT16 - fabric 03 - up red

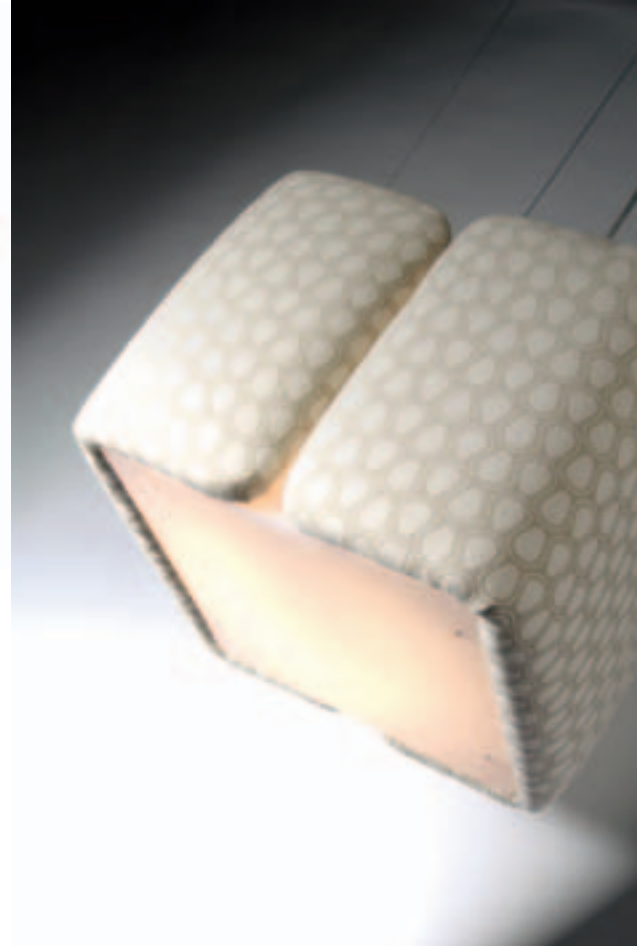

CHUBBY BOX - fabric 10 - down white plexi - up clear

CHUBBY S

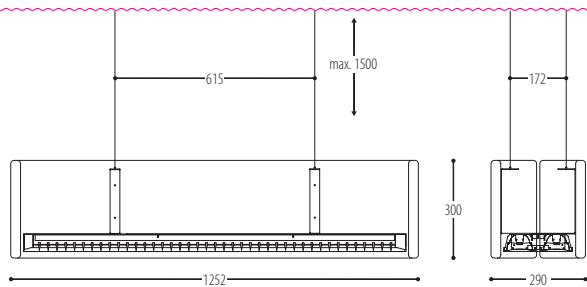

		DOWN	UP
	2x T16 (28 W) / G5		<input type="checkbox"/> Clear <input checked="" type="checkbox"/> Red <input checked="" type="checkbox"/> Mokka
	2x T16 (54 W) / G5		

		DOWN	
	5x QR-LP111 (MAX 45 W) / G53		black white
	5x HIT-TC-CE (20 W) / PGJ5		
	5x HIT-TC-CE (35 W) / PGJ5		

CHUBBY BOX

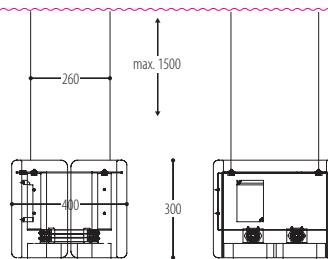

		DOWN	UP
	2x TC-TEL (32 W) / GX24q-3	silver gold white plexi	<input type="checkbox"/> Clear <input checked="" type="checkbox"/> Mokka

		DOWN	
	4x QR-LP111 (MAX 45 W) / G53		black white
	4x HIT-TC-CE (20 W) / PGJ5		
	4x HIT-TC-CE (35 W) / PGJ5		

CHUBBY FLOOR

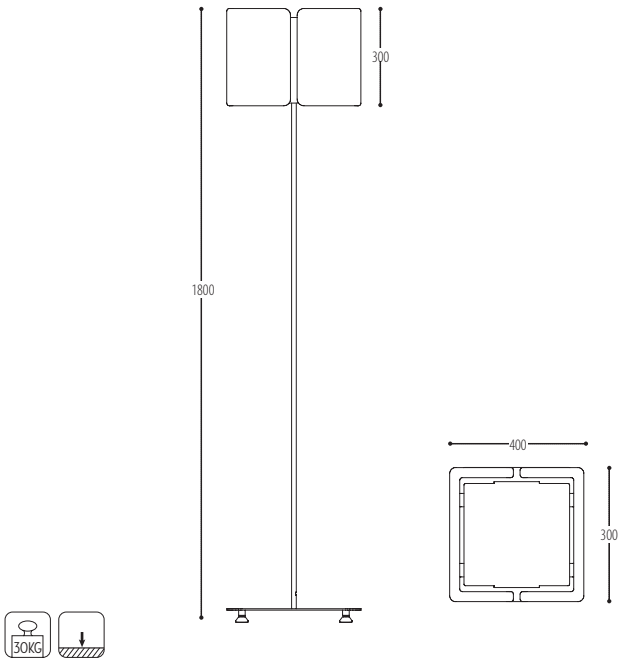

		DOWN	UP
	2x TC-TEL (32 W) / GX24q-3		

FABRICS - flame retardant



fabric 03



fabric 01



fabric 06



fabric 07

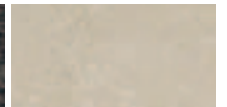

fabric 08



fabric 09

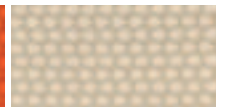

fabric 10



fabric 11



fabric 12

Fabric | Metal



CHUBBY S T16 D/ID BAP 60°/CLEAR

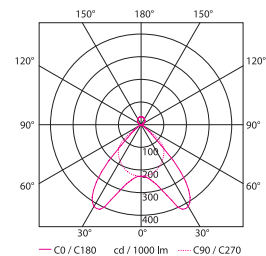

Efficiency factor: 70,29%

PROJECT PAGES:

019 - 110 - 141 - 168

COPPERFIELD

design Maximal Design for Dark

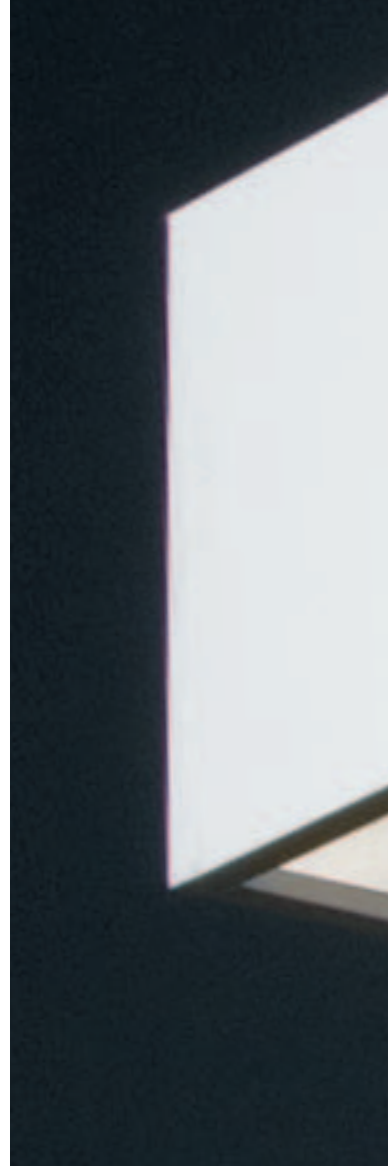



COPPERFIELD white



COPPERFIELD
black

COPPERFIELD

TECHNICAL SHEET

47

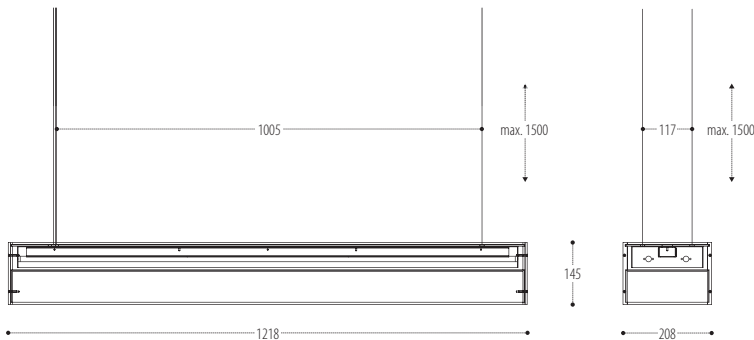
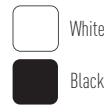

COPPERFIELD 2x28W

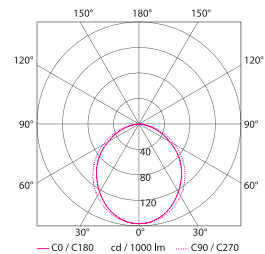

Efficiency factor: 40.8%

COUTURE

design Alain Berteau for Dark





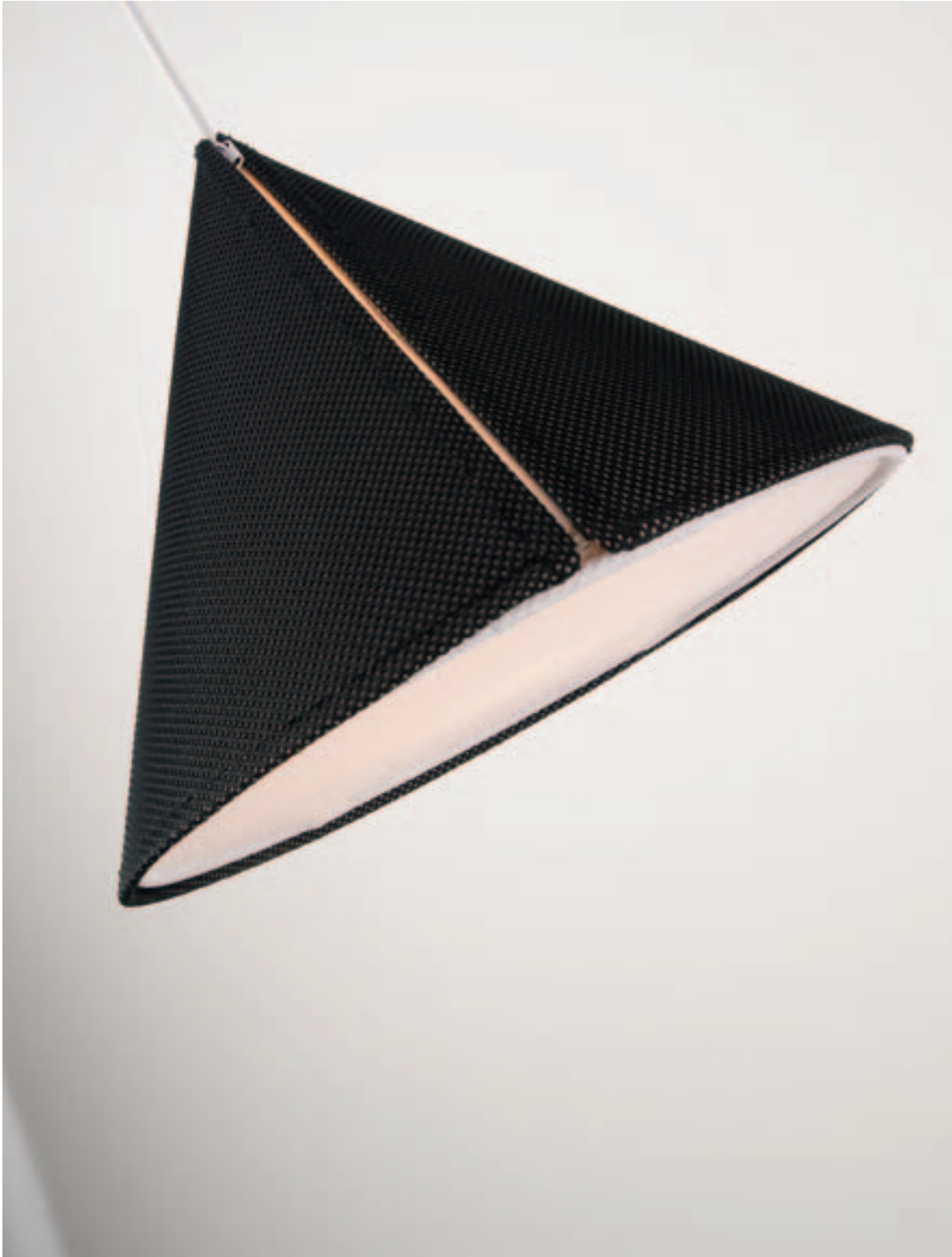

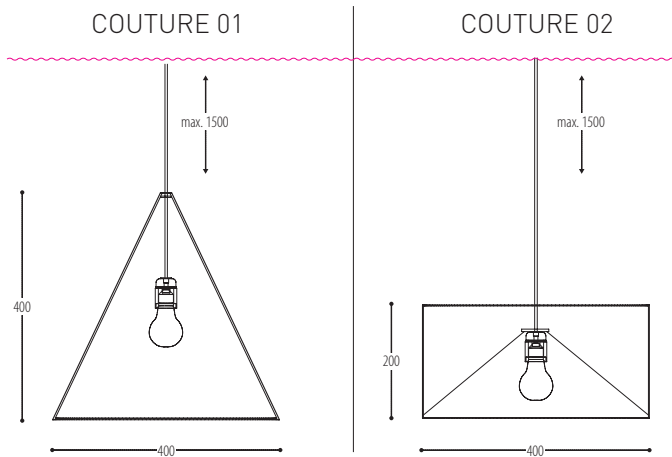

FABRICS



fabric 01



fabric 04







fabric 05



fabric 06

Fabric	Metal
--------	-------

-  1x A60 (MAX 60 W) / E27
-  1x QA60 (MAX 42 W) / E27
-  1x TCA-SE (MAX 11 W) / E27
-  1x LED (MAX 7 W) / E27



CROSSLIGHT

design Jan Melis & Ben Oostrum for Dark



reddot design award
winner 2003



Designpreis der
Bundesrepublik
Deutschland
Nominiert 2004



USA 2004

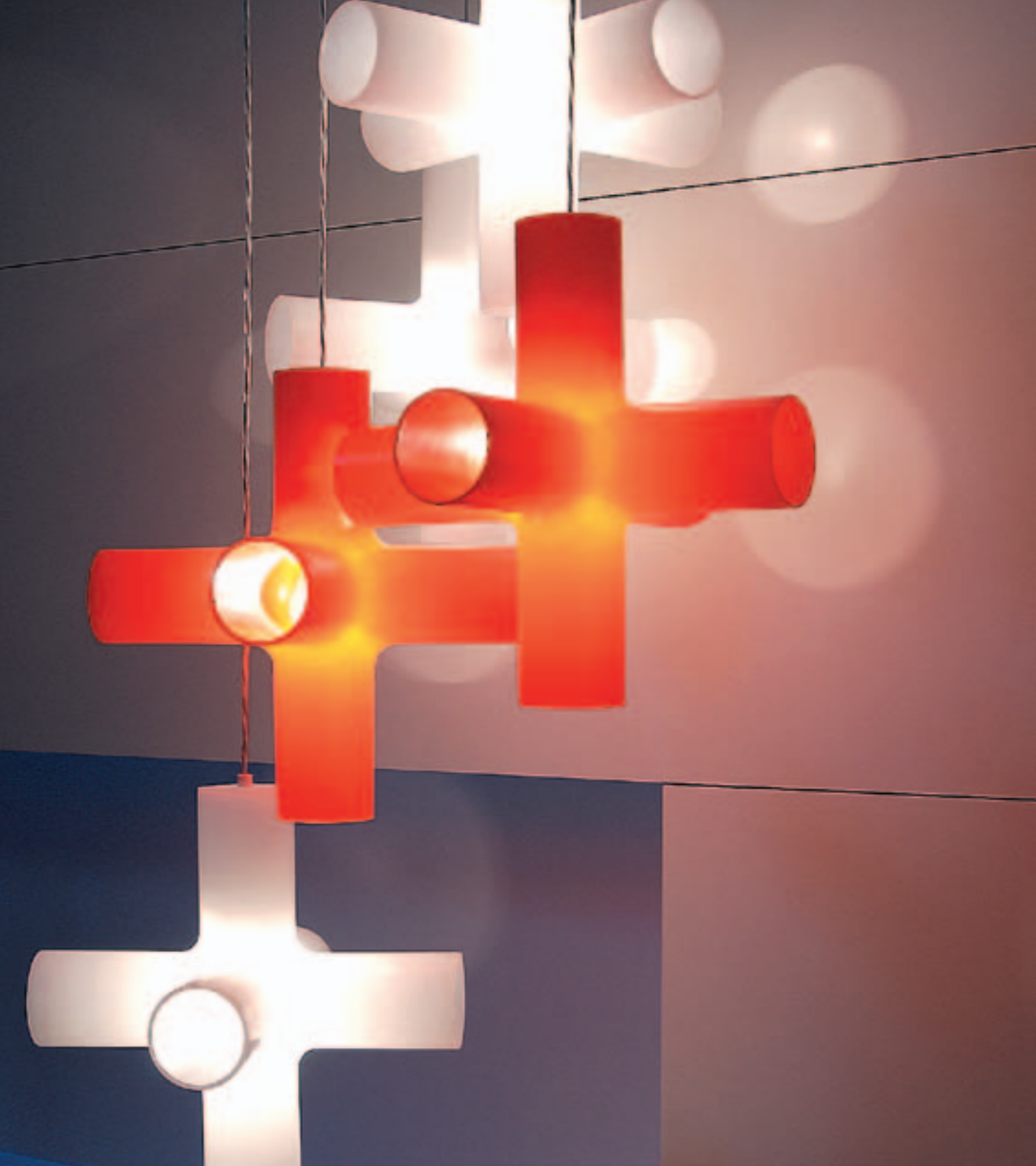



CROSSLIGHT S white



CROSSLIGHT S orange



CROSSLIGHT S red

CROSSLIGHT S

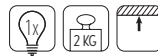
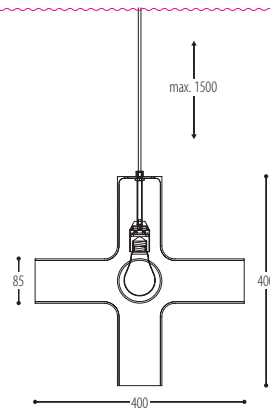

CROSSLIGHT WALL

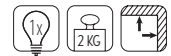
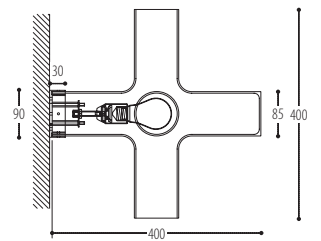

CROSSLIGHT 3P

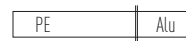
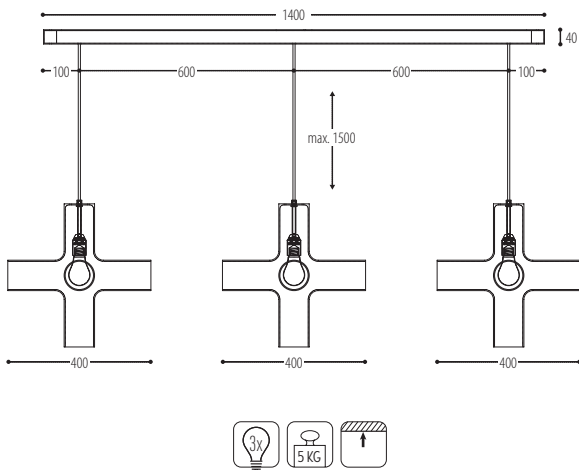

CROSSLIGHT white

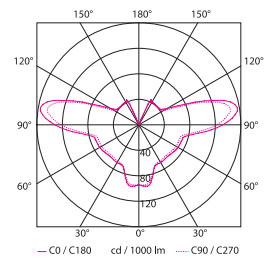

Efficiency factor: 80,3%

PROJECT PAGES:

031 - 037 - 090 - 091 - 097 - 101 - 109 -
116 - 149 - 156 - 159 - 179 - 188

CYBE

design Peter Vanooteghem for Dark



CYBE FLOOR
fluo red

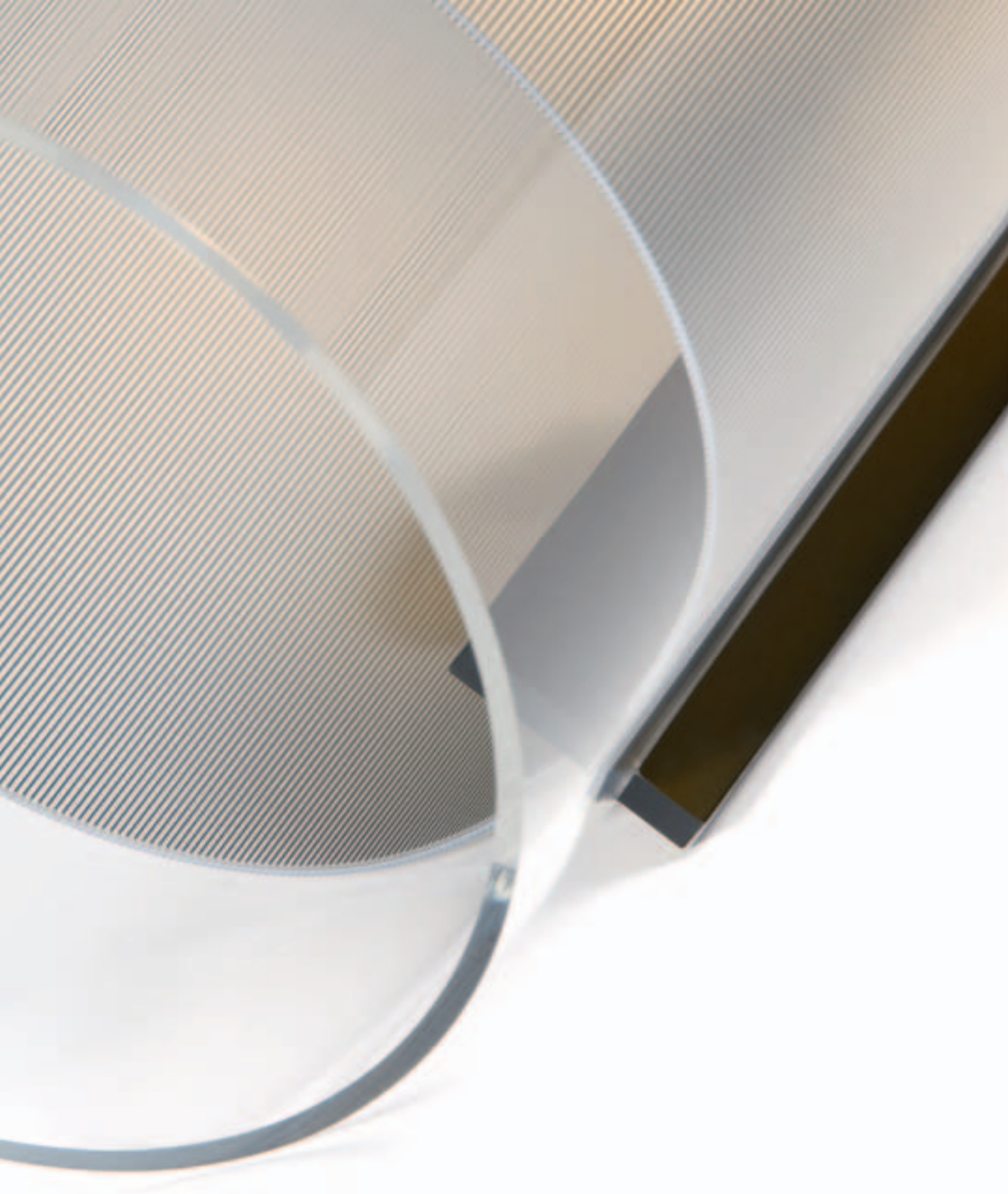



CYBE PLUG-IN mokka



CYBE TABLE fluo green

CYBE WALL fluo green





CYBE fluo red



CYBE fluo orange



CYBE fluo green



CYBE fluo blue



CYBE mokka

CYBE

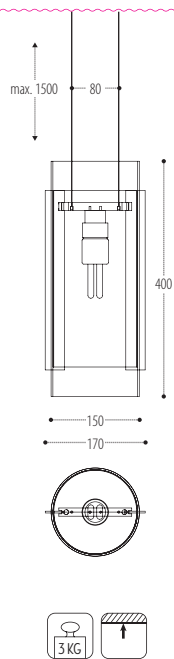

CYBE MAX

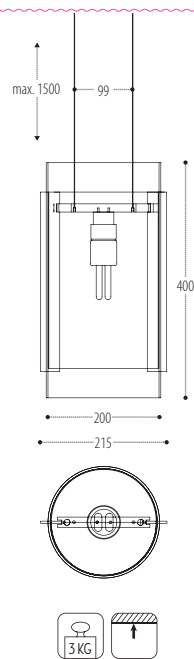

CYBE TABLE

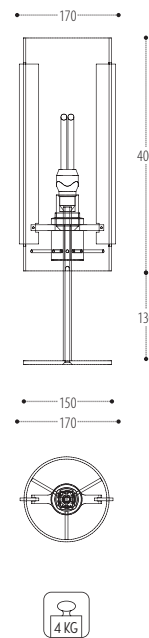

CYBE FLOOR

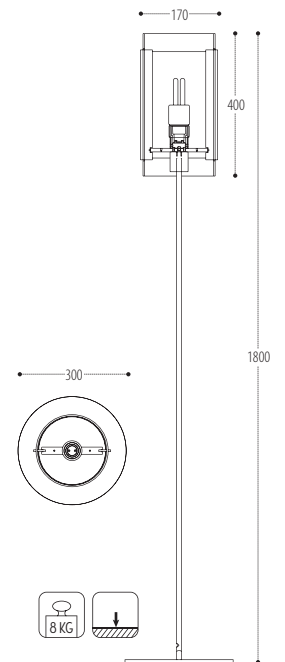

CYBE PLUG-IN

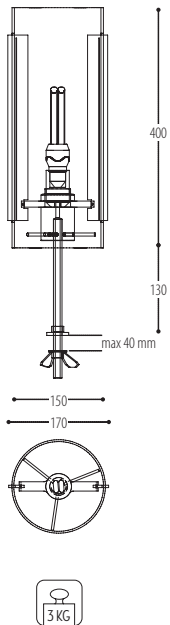

CYBE WALL

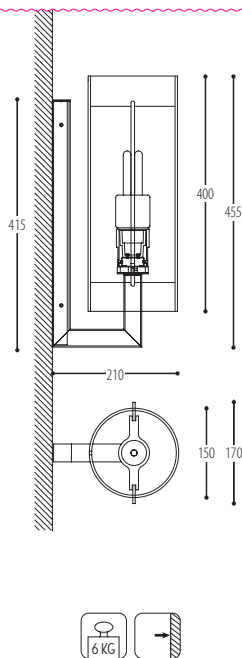

PROJECT PAGES:

082 - 091 - 137 - 163 - 185

d-BEEF

design Ivan Missinne for Dark

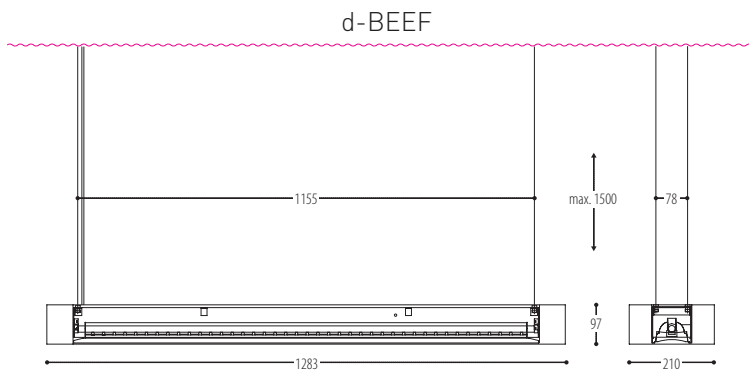

d-BEEF - 1xT16 (54W) - up.red





BODY (Wood)

UPLIGHT PLEXI

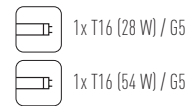
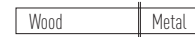

d-BEEF 1xT16 54W

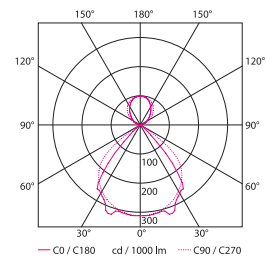

Efficiency factor: 81,2%

d-CONCRETE

design Ivan Missinne for Dark

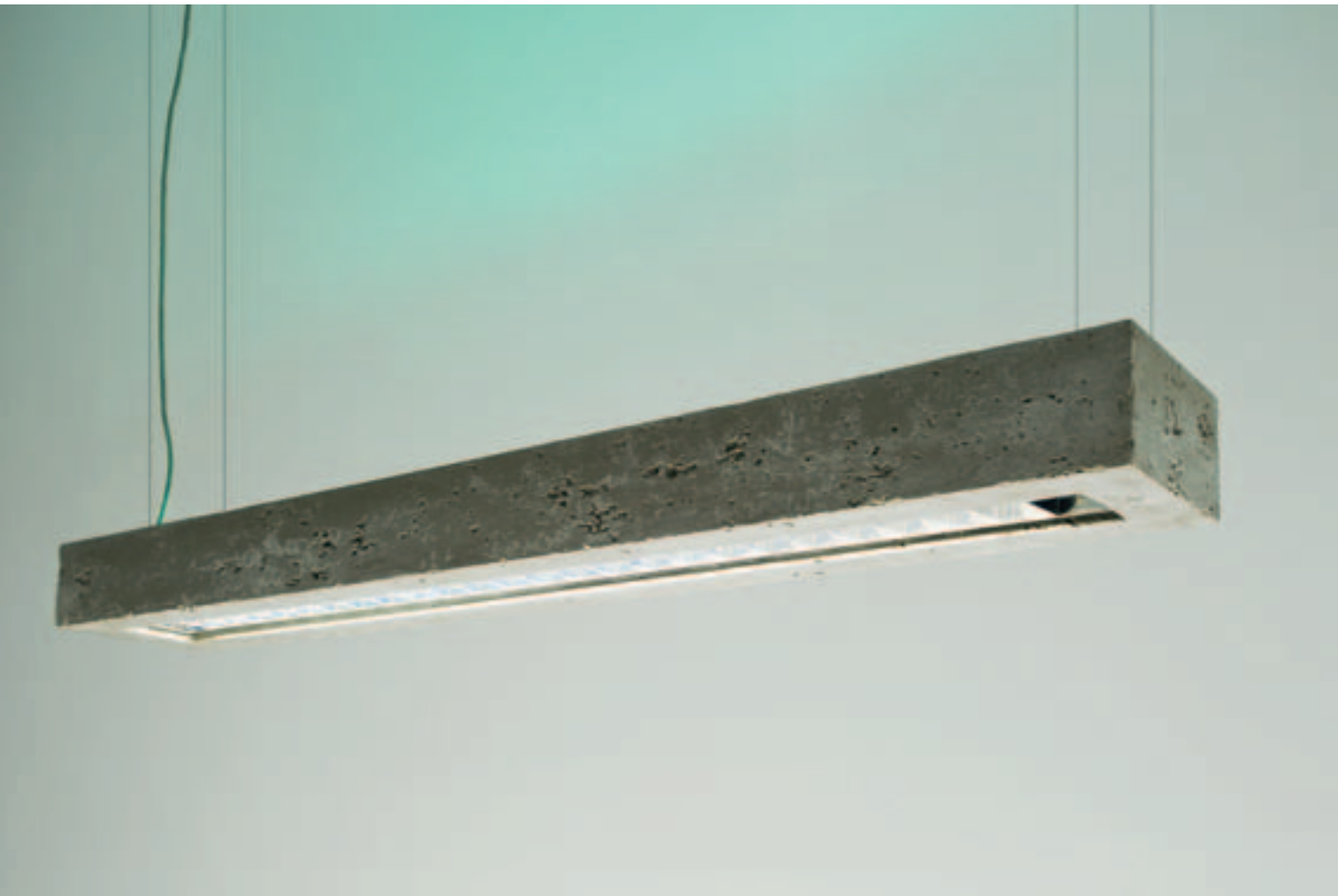

d-CONCRETE

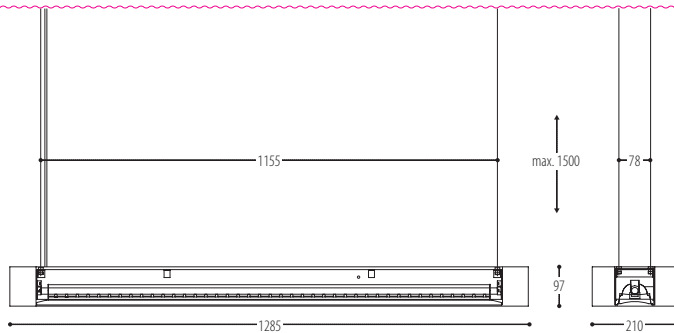

BODY (Concrete)

UPLIGHT PLEXI

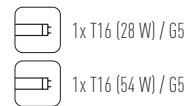
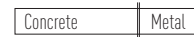

d-CONCRETE 1xT16 54W

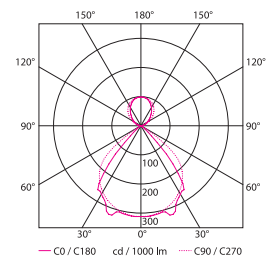

Efficiency factor: 81,2%

PROJECT PAGES:

008 - 112 - 190 - 191

d-COW

design Ivan Missinne for Dark



d-COW
1xT16 (54W)
up blue

d-COW

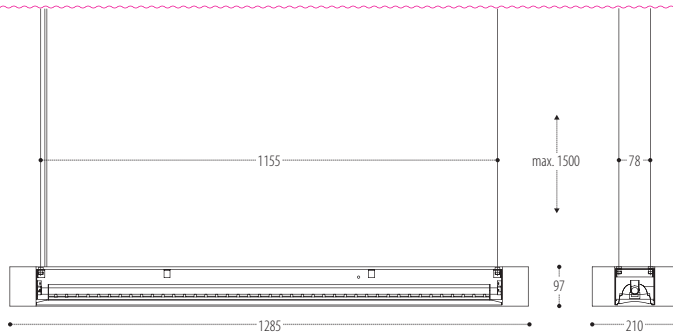

BODY (Cow Skin)

UPLIGHT PLEXI

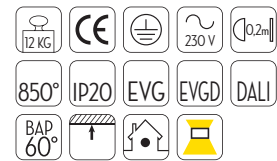
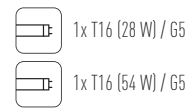

d-COW 1xT16 54W

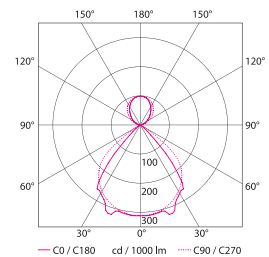

Efficiency factor: 81,2%

d-RABBIT

design Ivan Missinne for Dark

d-RABBIT white - 1xT16 (54W) - up clear





d-RABBIT black
1xT16 (54W)
up clear

BODY (Rabbit Fur)

- White
- Brown
- Black

UPLIGHT PLEXI

- Clear
- Red
- Blue
- Green



12 KG
CE
Earth symbol
230 V
0.2m
85°
IP20
EVG
EVGD
DALI
BAP 60°
Up arrow
House icon
Light fixture icon

d-RABBIT

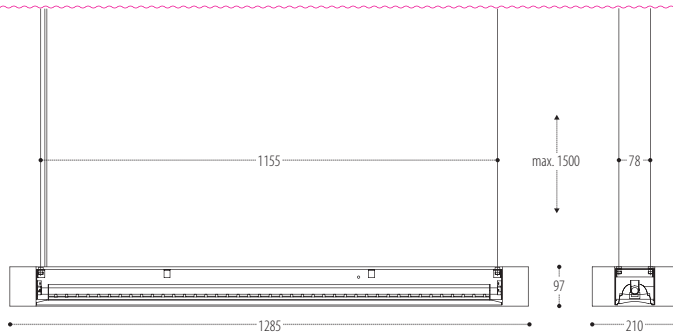

d-RABBIT 1xT16 54W

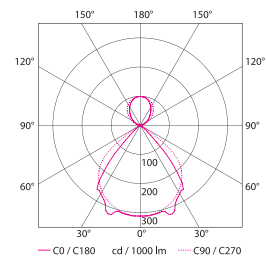

Efficiency factor: 81,2%

70

d-LEATHER

design Ivan Missinne for Dark

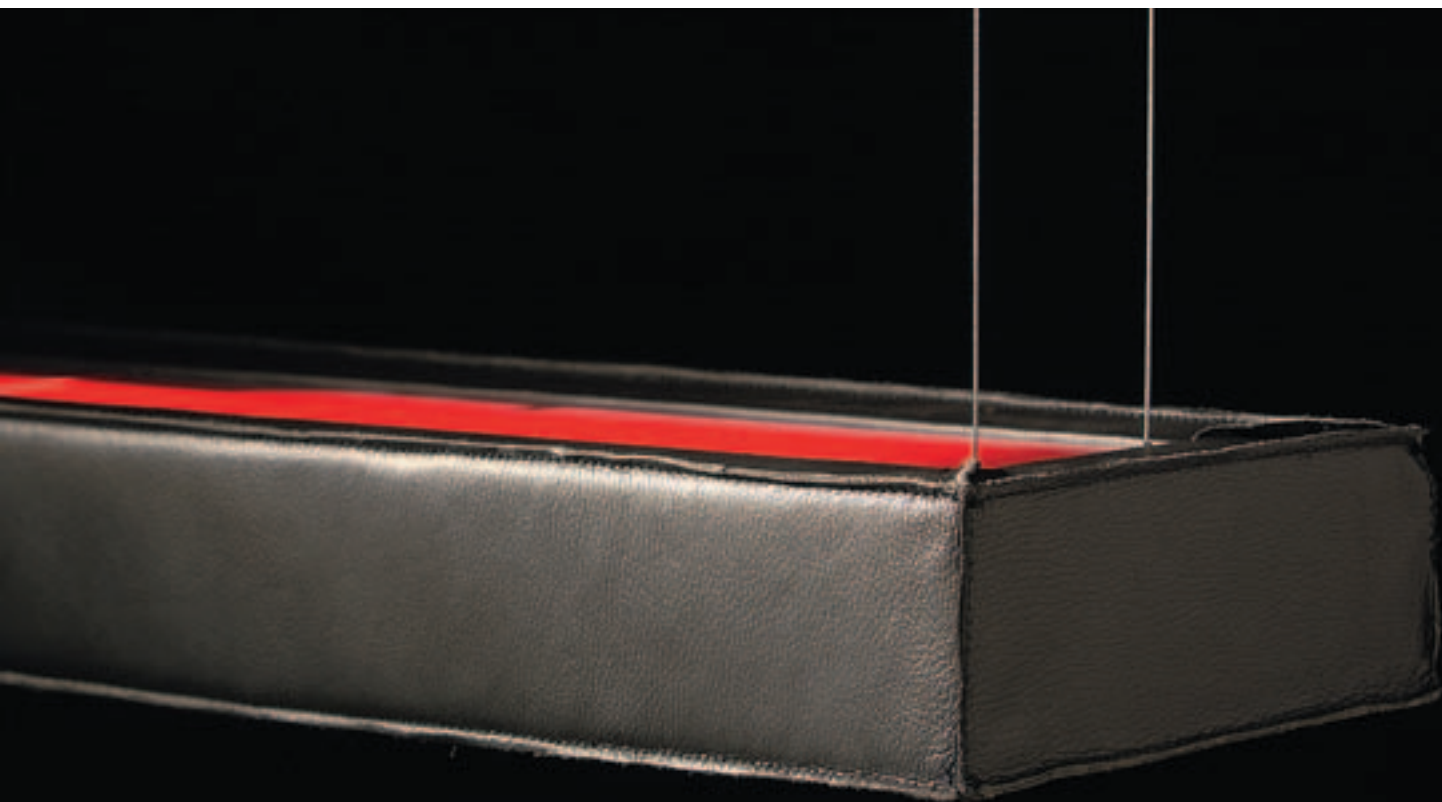

d-LEATHER black -1xT16 (54W) - up red

d-LEATHER

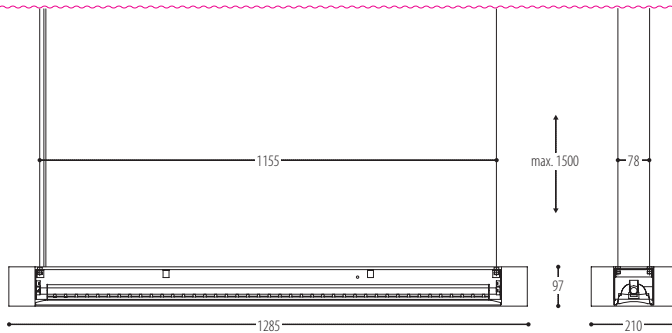

BODY (Leather)



UPLIGHT PLEXI

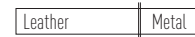

d-LEATHER 1xT16 54W

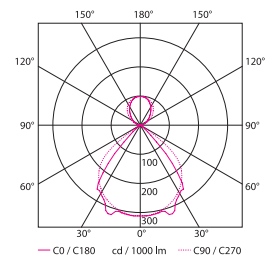

Efficiency factor: 81.2%

PROJECT PAGES:

081

d-SQUEEZE

design Ivan Missinne for Dark



d-SQUEEZE white - 1xT16 (54W) - up blue



d-SQUEEZE

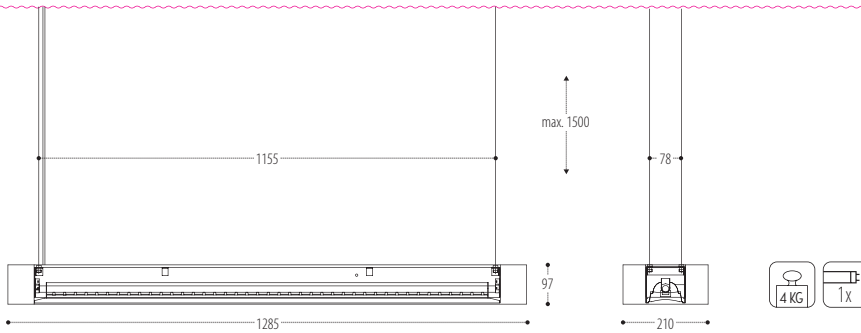

d-SQUEEZE double

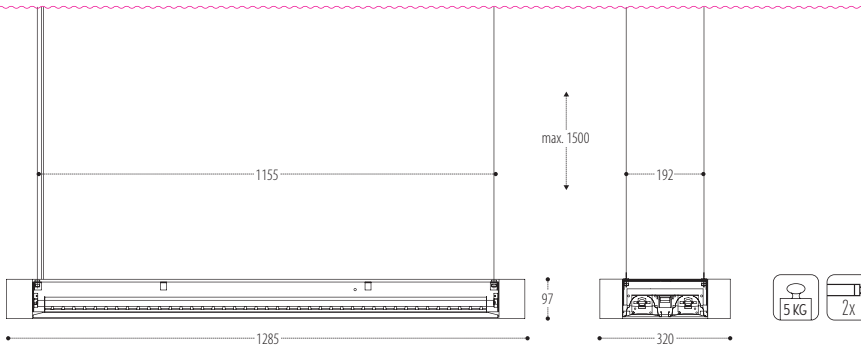

BODY (foam)



UPLIGHT PLEXI

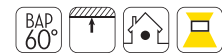

d-SQUEEZE double 2xT16 54W

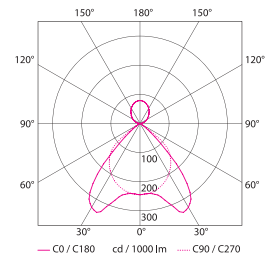

Efficiency factor: 75,83%

PROJECT PAGES:

114 - 144

D2V2

design Danny Venlet for Dark



reddot design award
winner 2003



Designpreis der
Bundesrepublik
Deutschland
Nominiert 2004



U S A 2 0 0 4





red coloured bulbs



blue coloured bulbs



green coloured bulbs

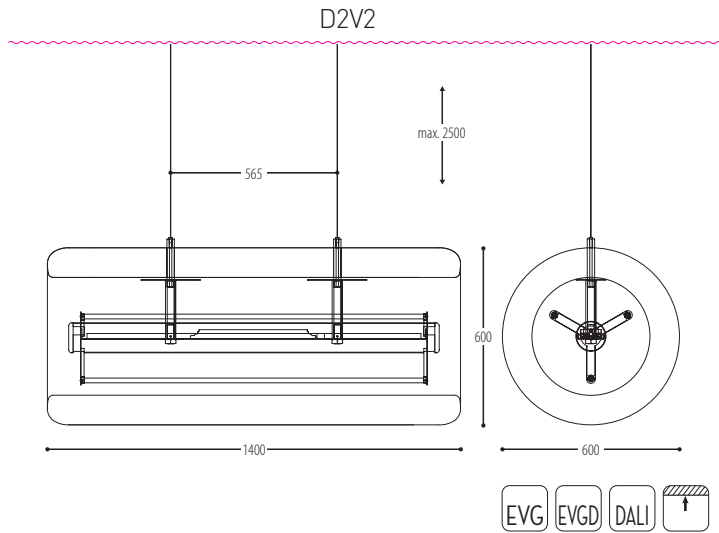

D2V2 FLOOR

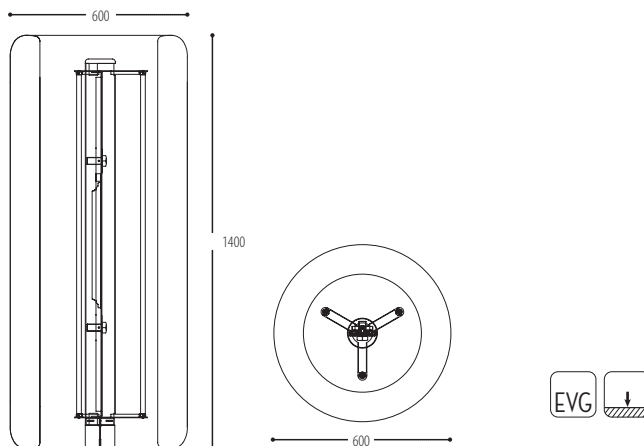

BODY



WITH COLOURED BULBS



D2V2 3x54W

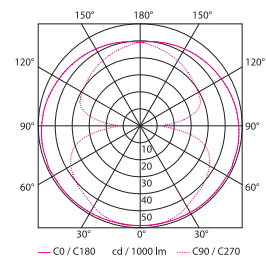

Efficiency factor: 64,4%

PROJECT PAGES:

012 - 026 - 028 - 063 - 117 - 138 - 143 -
155 - 180 - 185

FRANJE

design Marcel Reulen for Dark



FRANJE FLOOR white

FRANJE TABLE white

FRANJE S black





FRANJE TABLE

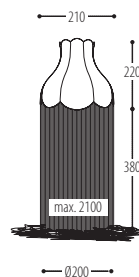

FRANJE WALL

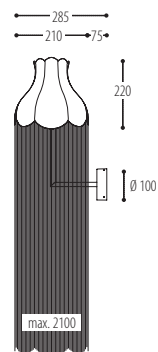

FRANJE FLOOR

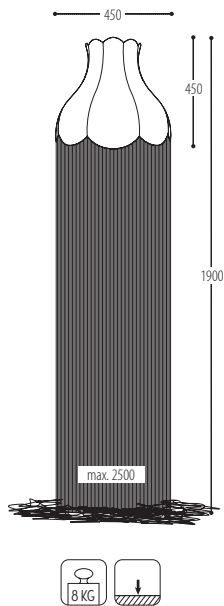

FRANJE S

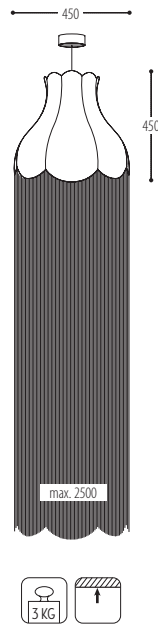

FABRICS - flame retardant

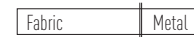

FRANJE TABLE / FRANJE WALL



FRANJE FLOOR / FRANJE S



PROJECT PAGES:

060 - 064 - 073 - 096 - 162 - 169 - 170

GUM

design Claesson-Koivisto-Rune for Dark

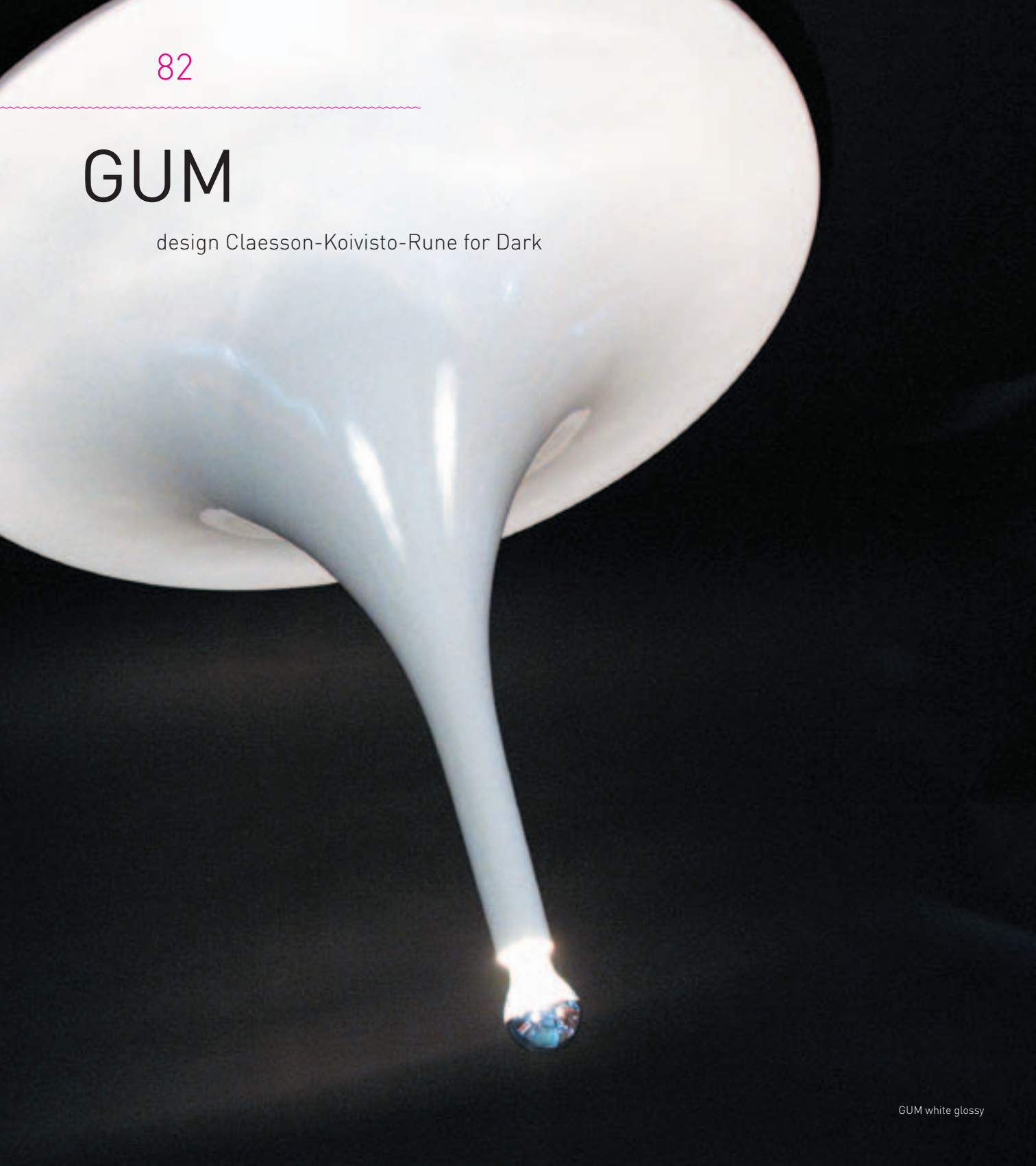

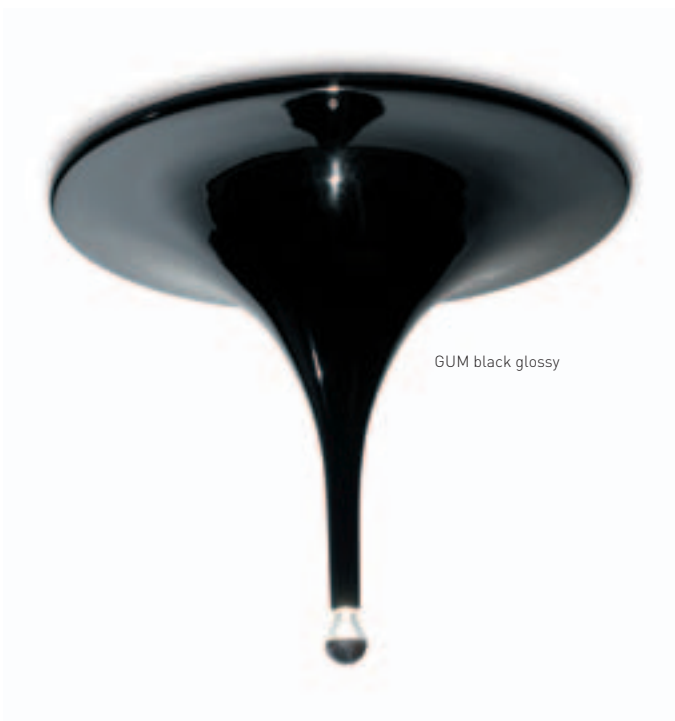

GUM black glossy

-  White glossy
-  Black glossy

 On request

Polyester | Metal

 1x A60-CS-G (MAX 60 W) / E27









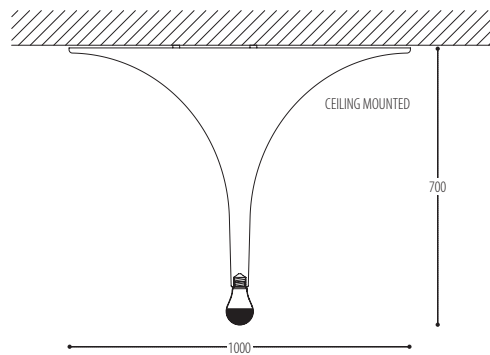

HEAPS

design Marnick Smessaert for Dark

HEAPS 2 print 03





HEAPS BOX
print 05



HEAPS 2 red



HEAPS 2 wood

YOU CAN CREATE YOUR OWN HEAPS PRINT

from digital photo

Specifications digital photo:
dimensions: 1085 x 150mm
resolution: 300 dpi
colour mode : CMYK
format : JPG, TIFF, PDF, EPS

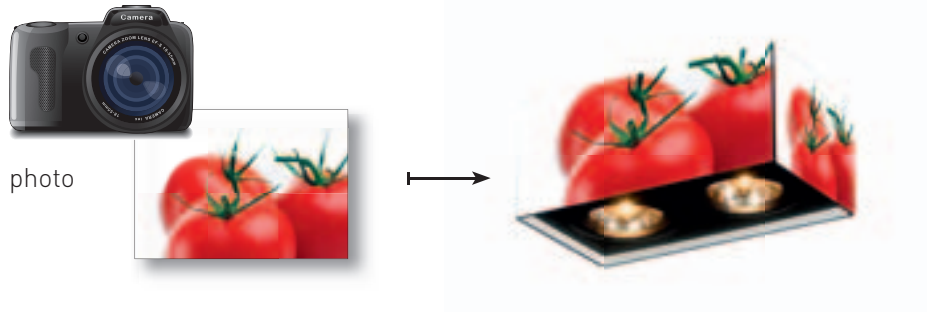

from graphics vector document

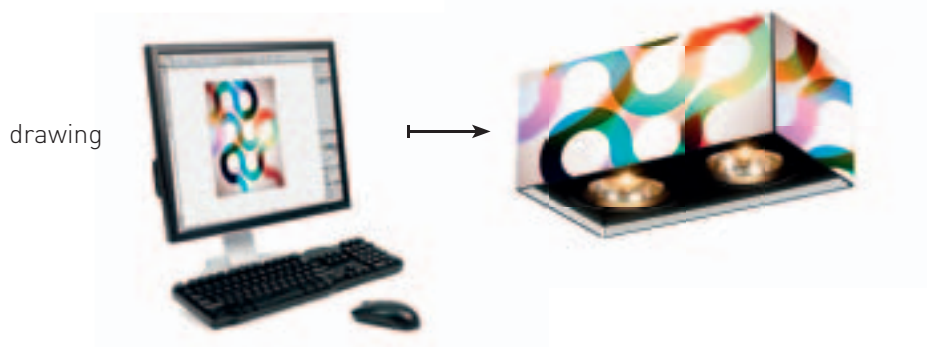
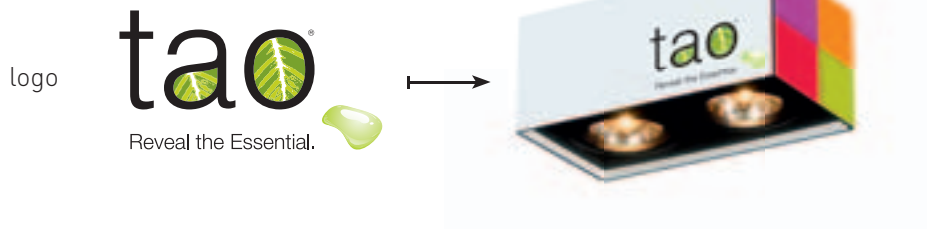

PRINTS

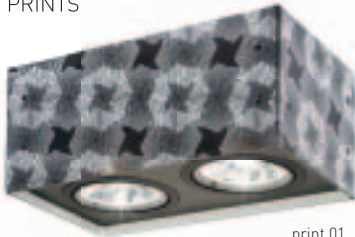

print 01

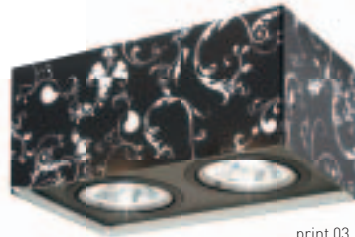

print 03

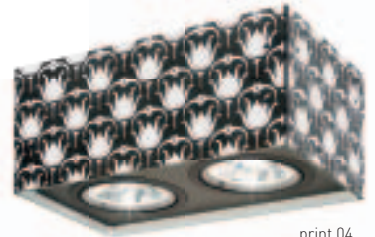

print 04



print 05

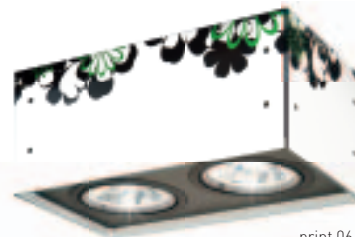

print 06

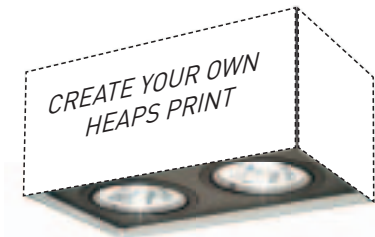

HEAPS 2

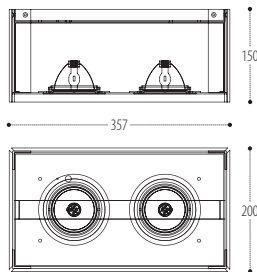

		DOWN
	2x QR-LP111 (MAX 45 W) / G53	black
	2x HIT-TC-CE (20 W or 35 W) / PGJ5	white

HEAPS 3

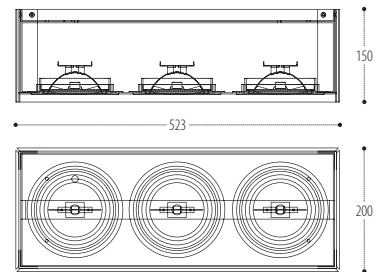

		DOWN
	3x QR-LP111 (MAX 45 W) / G53	black
	3x HIT-TC-CE (20 W or 35 W) / PGJ5	white



red



gold



white



wood

HEAPS 4

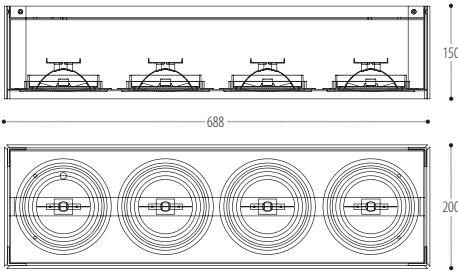

HEAPS 4 BOX

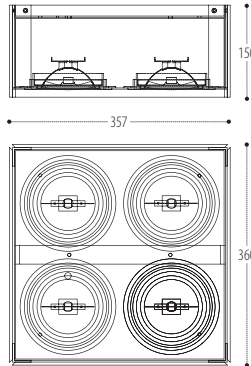

DOWN HEAPS 4

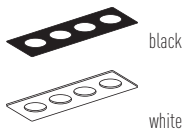

DOWN HEAPS 4 BOX

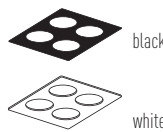

4x QR-LP111 (MAX 45 W) / G53

4x HIT-TC-CE (20 W or 35 W) / PGJ5

AW Metal

QR-LP111 (MAX 45 W) / G53

HIT-TC-CE (20 W or 35 W) / PGJ5



QR-LP111 45W-22°

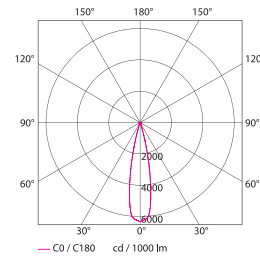

Efficiency factor: 100%

QR-LP111 45W-45°

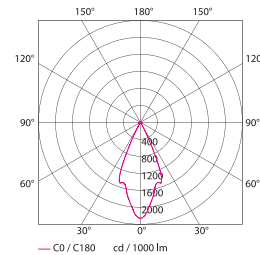

Efficiency factor: 100%

PROJECT PAGES:

138

HERBERT

design Fabien Dumas for Dark

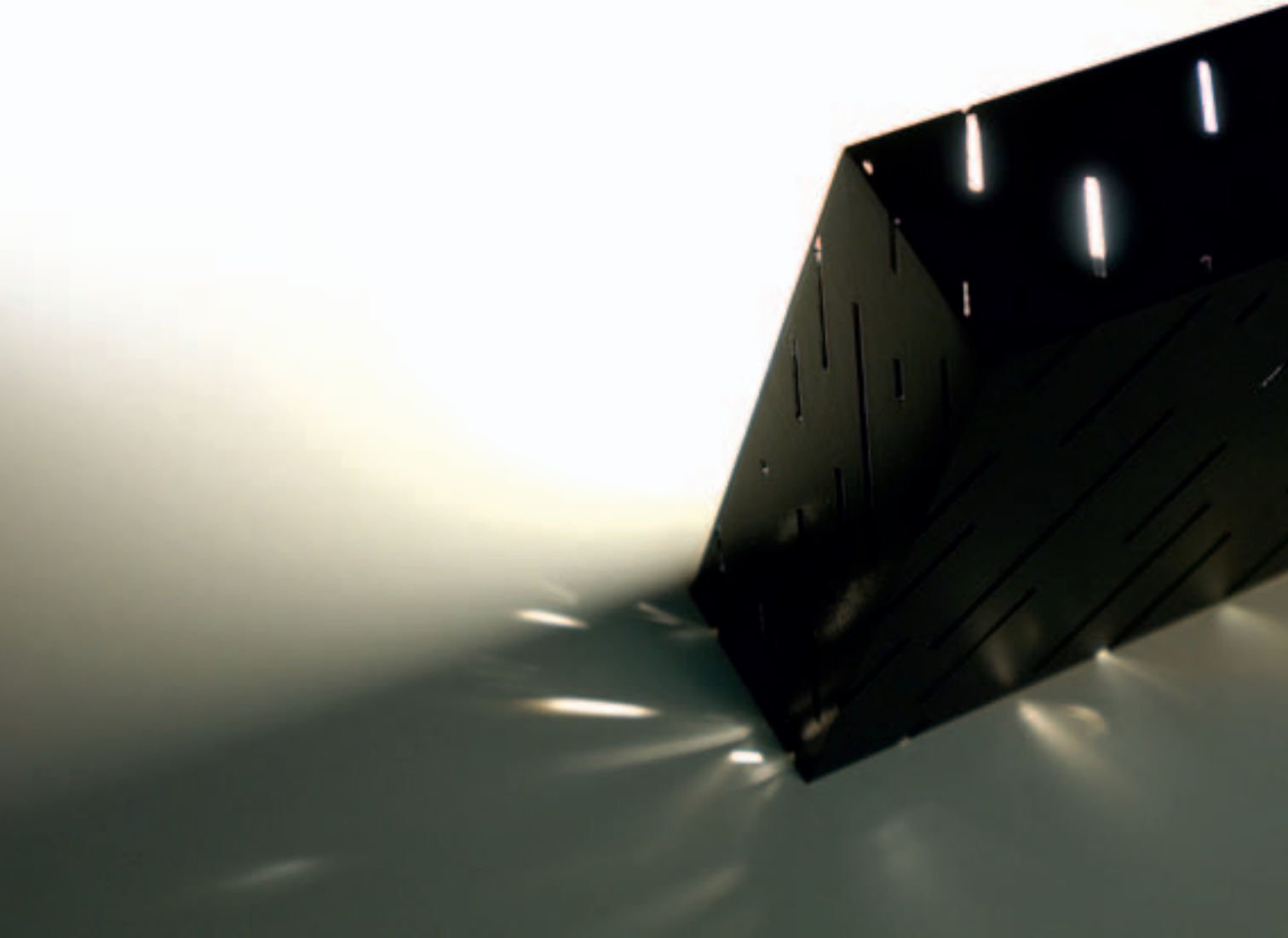



HERBERT 02 black

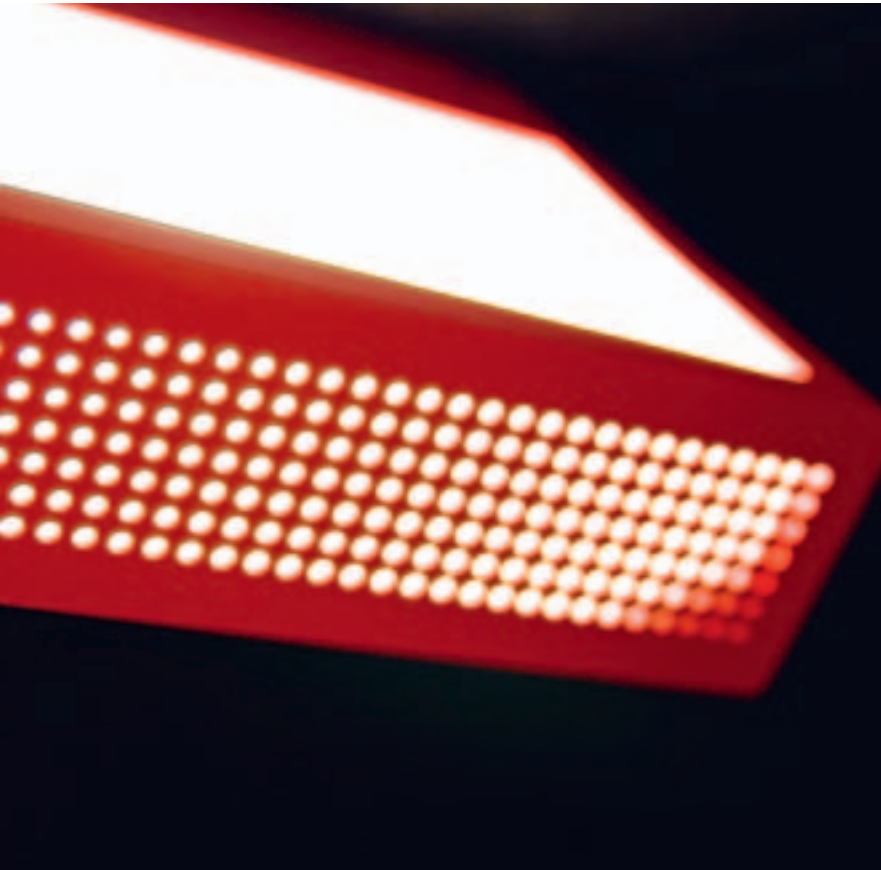

HERBERT 03 red

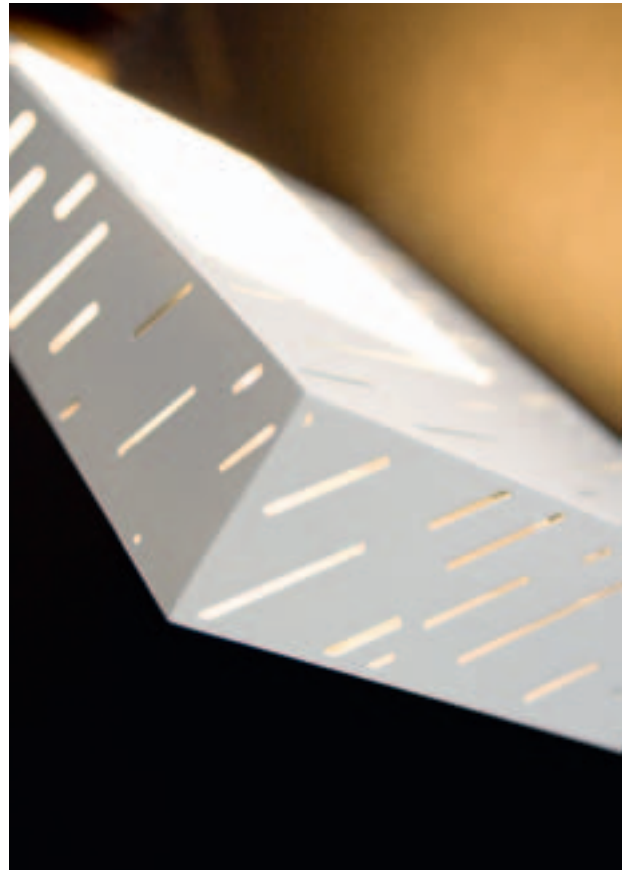

HERBERT 02 white

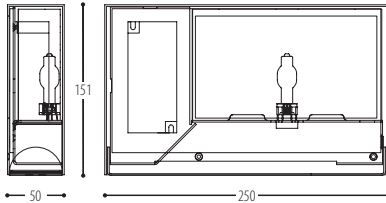

HERBERT can easily be switched from down to upright due to the magnet.

HERBERT 01

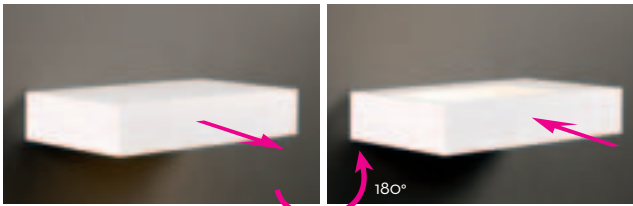

HERBERT 02

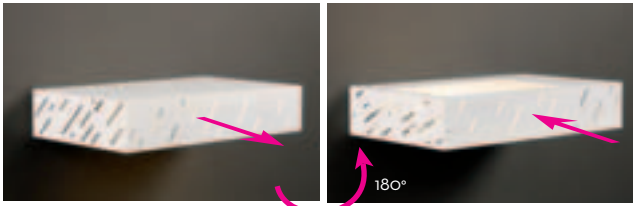

HERBERT 03

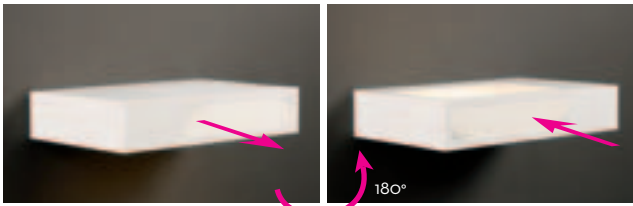

HERBERT 04

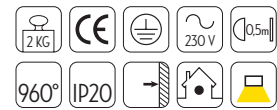
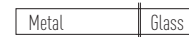
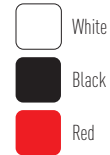
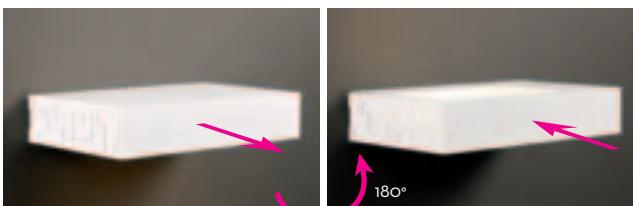

HERBERT 01 HIT-TC-CE

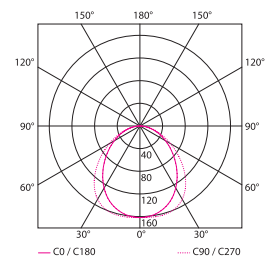

Efficiency factor: 42,8%

HOEK

design Jos Devriendt for Dark



HOEK black



- White
- Black

Metal

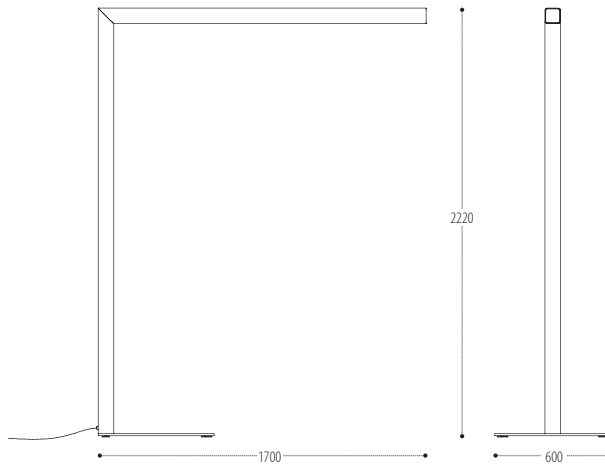

- 1x T16 (35 W) / G5
- 1x T16 (49 W) / G5

OPTIONAL

- BAP 60°
- OPAL

- 60 KG
- CE
- ⚡
- 230 V
- IP20
- 960°
- EVG
- ⚡
- INCL. GEAR
- [0.2m]
- [Yellow Triangle]

HOPPY

design Boo for Dark



DESIGNPREIS
2009
NOMINIERT



USA 2007



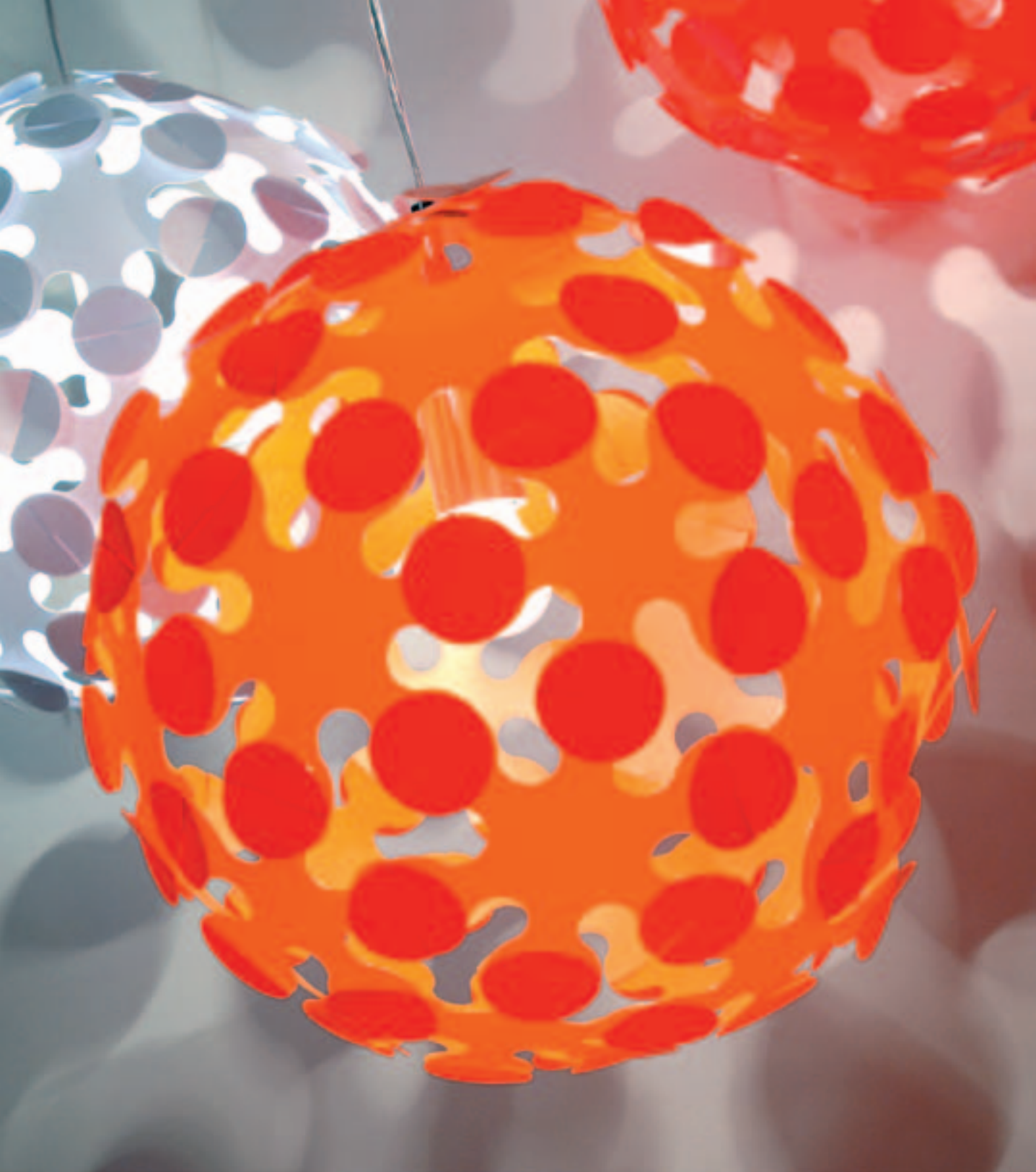



HOPPY black



HOPPY
white



HOPPY
orange

HOPPY
red

HOPPY
black

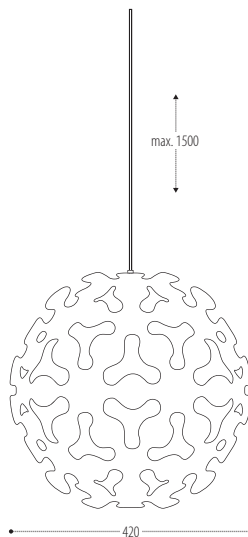
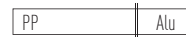
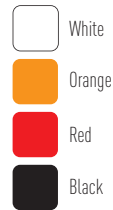

PROJECT PAGES:

025 - 059 - 061 - 068 - 069 - 100 - 101 -
142 - 148 - 188

100

HYPE

design Anthony Duffeleer for Dark





HYPE white

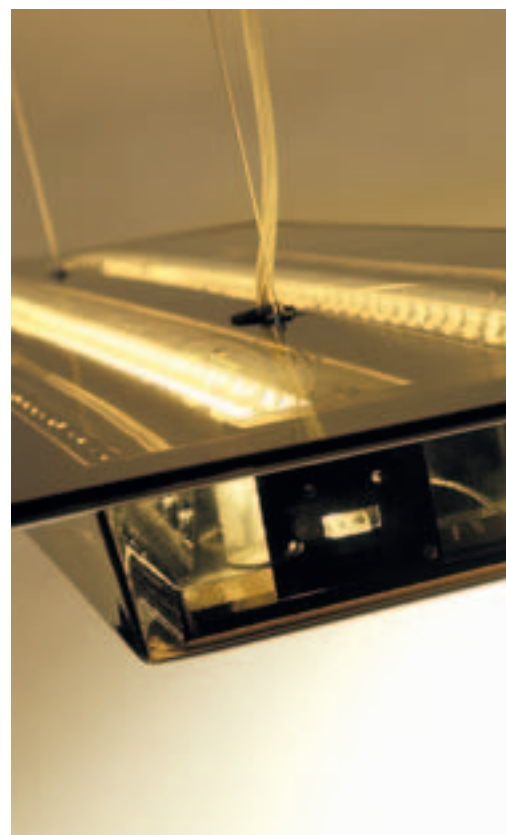

HYPE mokka



- Orange
- White
- Mokka

PMMA | Metal

2x T16 (28 W) / G5

850°	IP20	EVG	EVGD	DALI
BAD 60°				

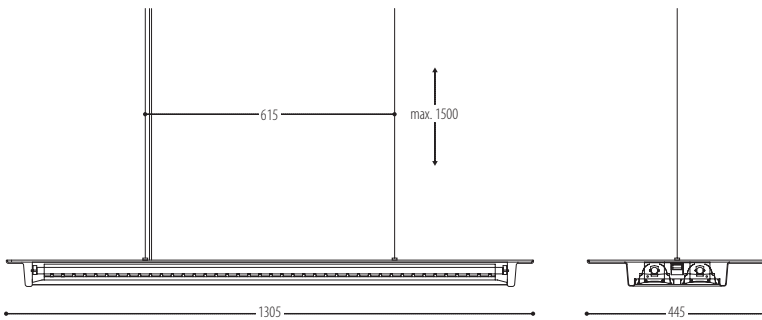

HYPE 2x28W

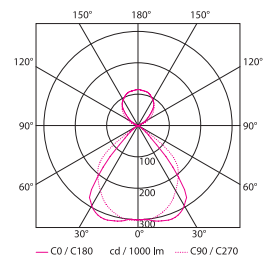

Efficiency factor: 82,6%

ICE

design Anthony Duffeleer for Dark

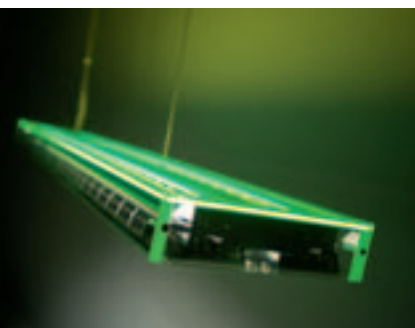

ICE - up blue - up red & up green ICE - up transparent

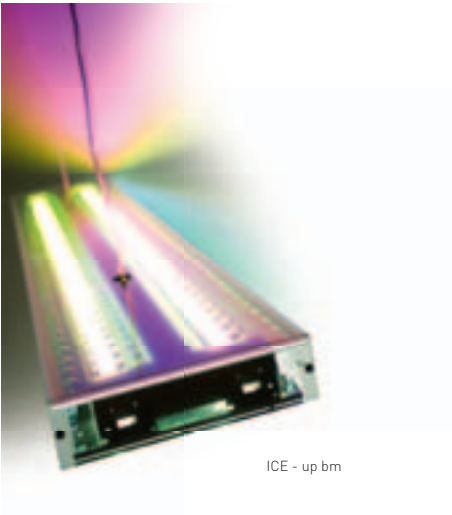



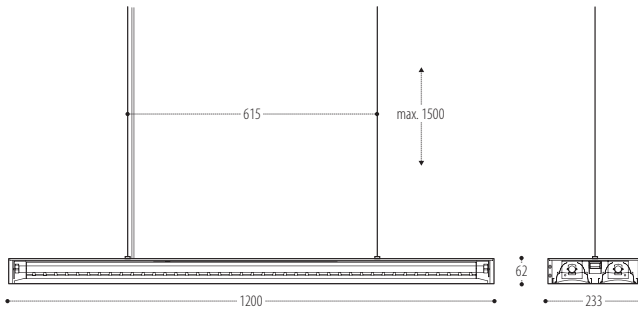

ICE - up bm





BODY

 Clear plexi

UPLIGHT PLEXI

 Clear  Red
 Blue  Green
 bm

 PMMA |  Metal

 2x T16 (28 W) / G5

 2x T16 (54 W) / G5



ICE 2x54W

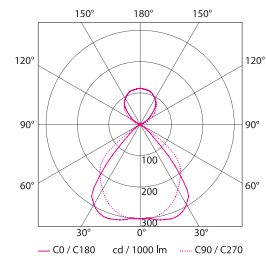

Efficiency factor: 82,6%

PROJECT PAGES:

013 - 040 - 047 - 069 - 089 - 094 - 099 -
131 - 147 - 176 - 183 - 186 - 191

JOHN PAWSON LAMP

design John Pawson for Dark



DESIGNPREIS
2009
NOMINIERT



USA 2007





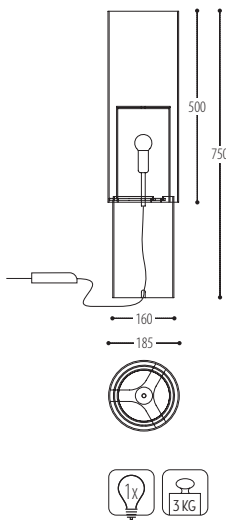
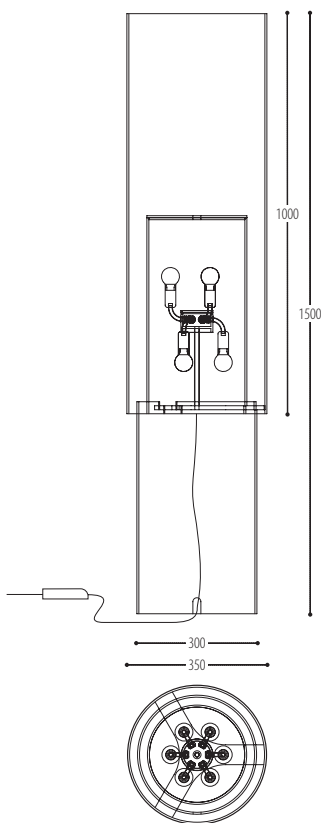

JOHN PAWSON
FLOOR LAMP

JOHN PAWSON
TABLE LAMP



BODY



-  D45 (MAX 40 W) / E14
-  QD45 (MAX 28 W) / E14
-  TCA-SE (MAX 7 W) / E14
-  LED (MAX 7 W) / E14



JUICE

design Ivan Missinne for Dark

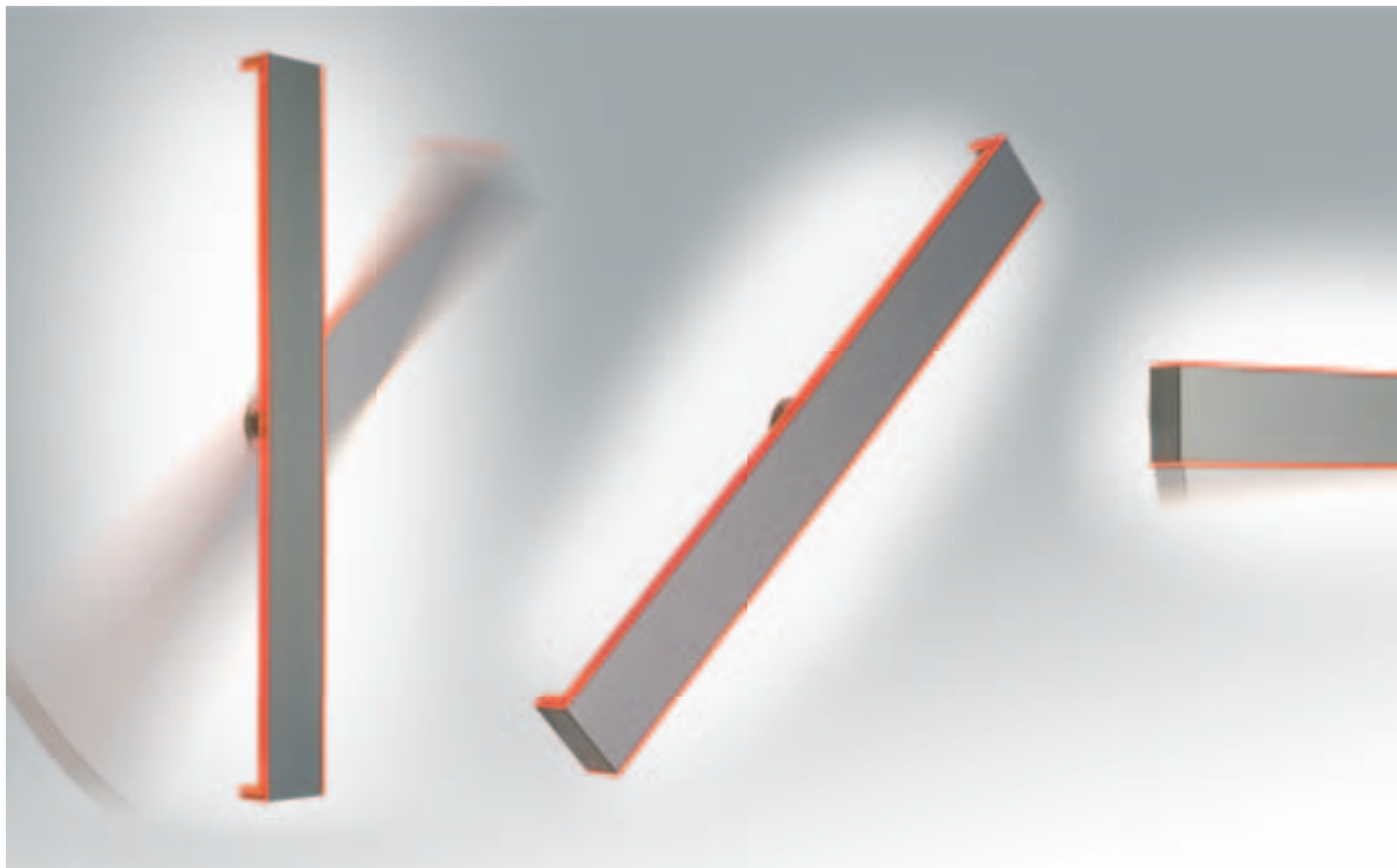

JUICE orange - 2x28W

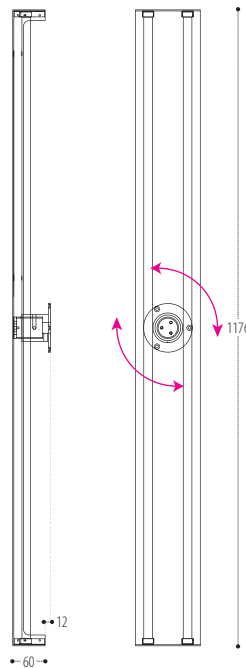
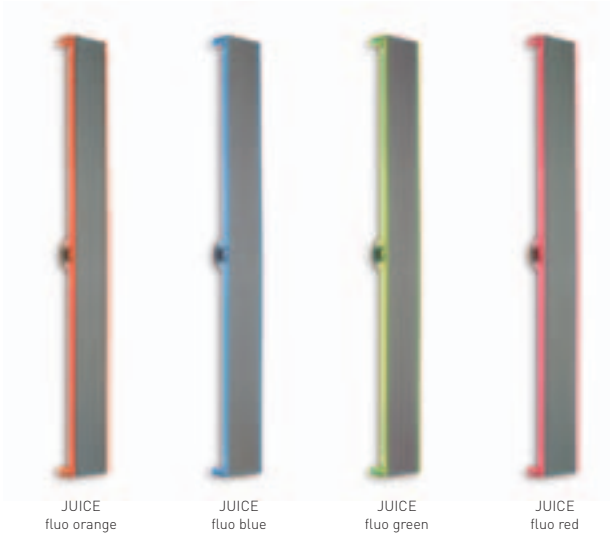

JUICE 2x28W

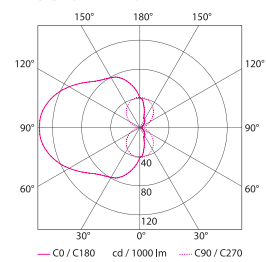

Efficiency factor: 49,74%

KNARF

design Frank Janssens for Dark



reddot design award
honourable mention 2009



KNARF

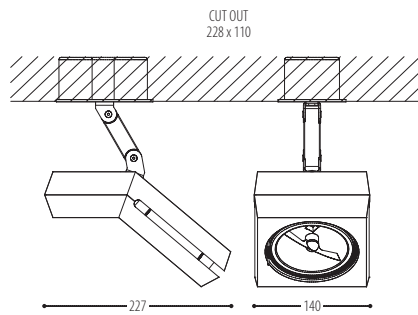

KNARF 0

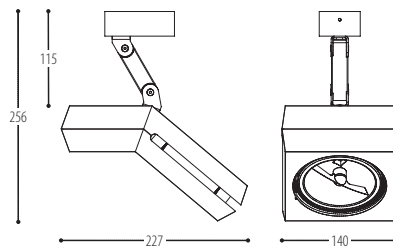

KNARF TRACK

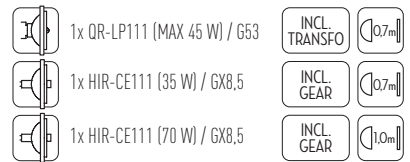
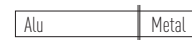
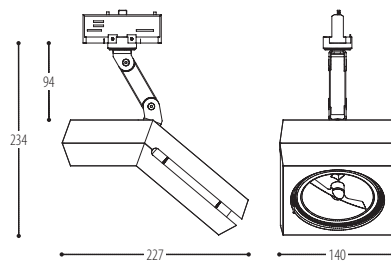

ACCESSORIES



QR-LP111 45W-22°

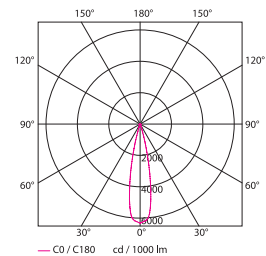

Efficiency factor: 100%

112

KNIK

design Jos Devriendt for Dark



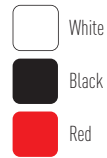
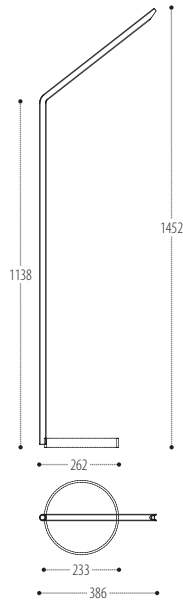

LA CAGE

design Stefan Schöning for Dark



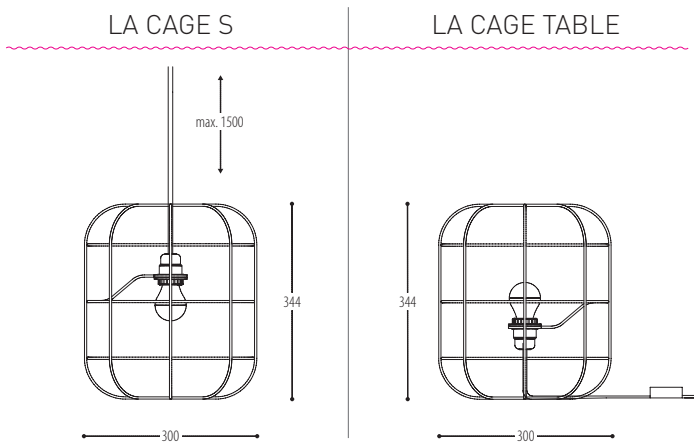





Black



Metal

-  1x D45 (MAX 40 W) / E14
-  1x OD45 (MAX 28 W) / E14
-  1x TCA-SE (MAX 7 W) / E14
-  1x LED (MAX 7 W) / E14



- LA CAGE S 
- LA CAGE TABLE 

PROJECT PAGES:
119

L-BOW

design Lars Pettersson and Morgan Rudberg for Dark



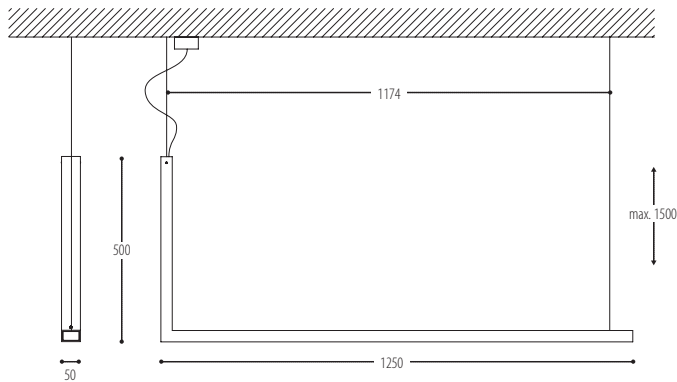

White



Black

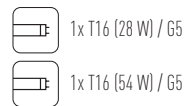

LGTM-X01

design Carl Hagerling for Dark







LGTM-X01 white

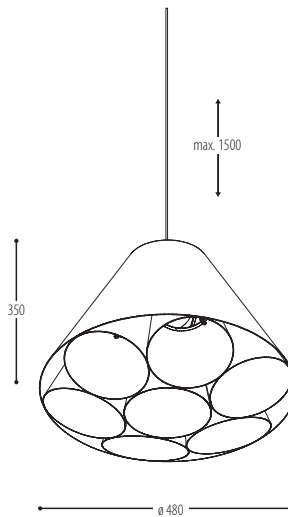

BODY

- White
- Black

INSIDE

- Gold

Metal

 1x G80 (MAX 60 W) / E27

 1x TCG-SE (MAX 15 W) / E27

    

122

LOOP

design Petter Knudsen for Dark

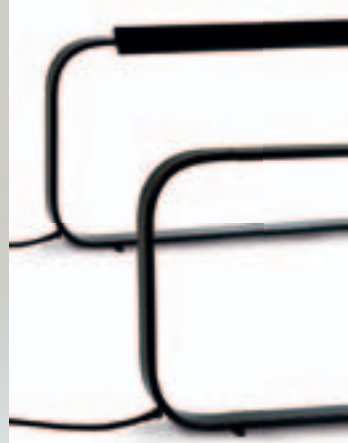

USA 2008

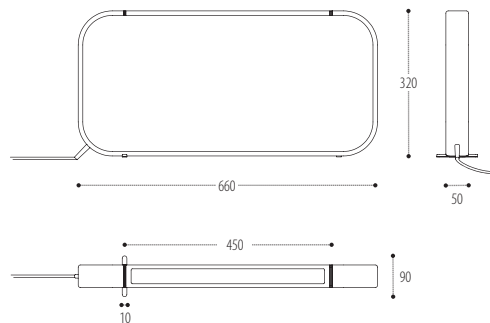
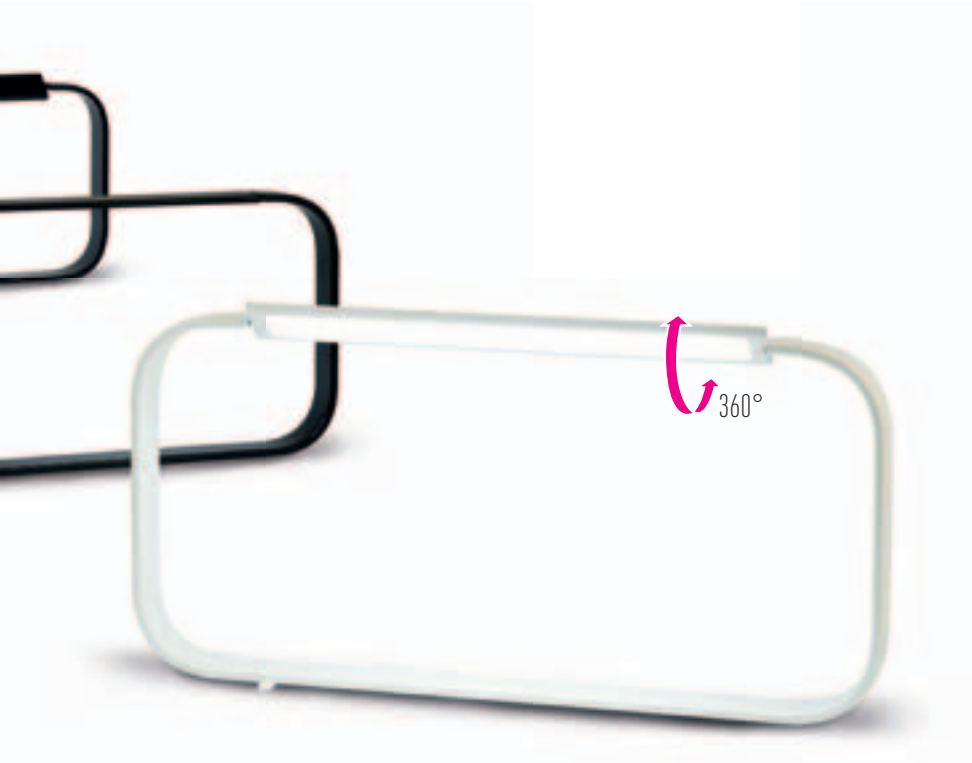

- White
- Black
- Chrome

Alu

LED Colour temp 3500K / 15 W



METROPOLIS

design Chris Jackson for Dark

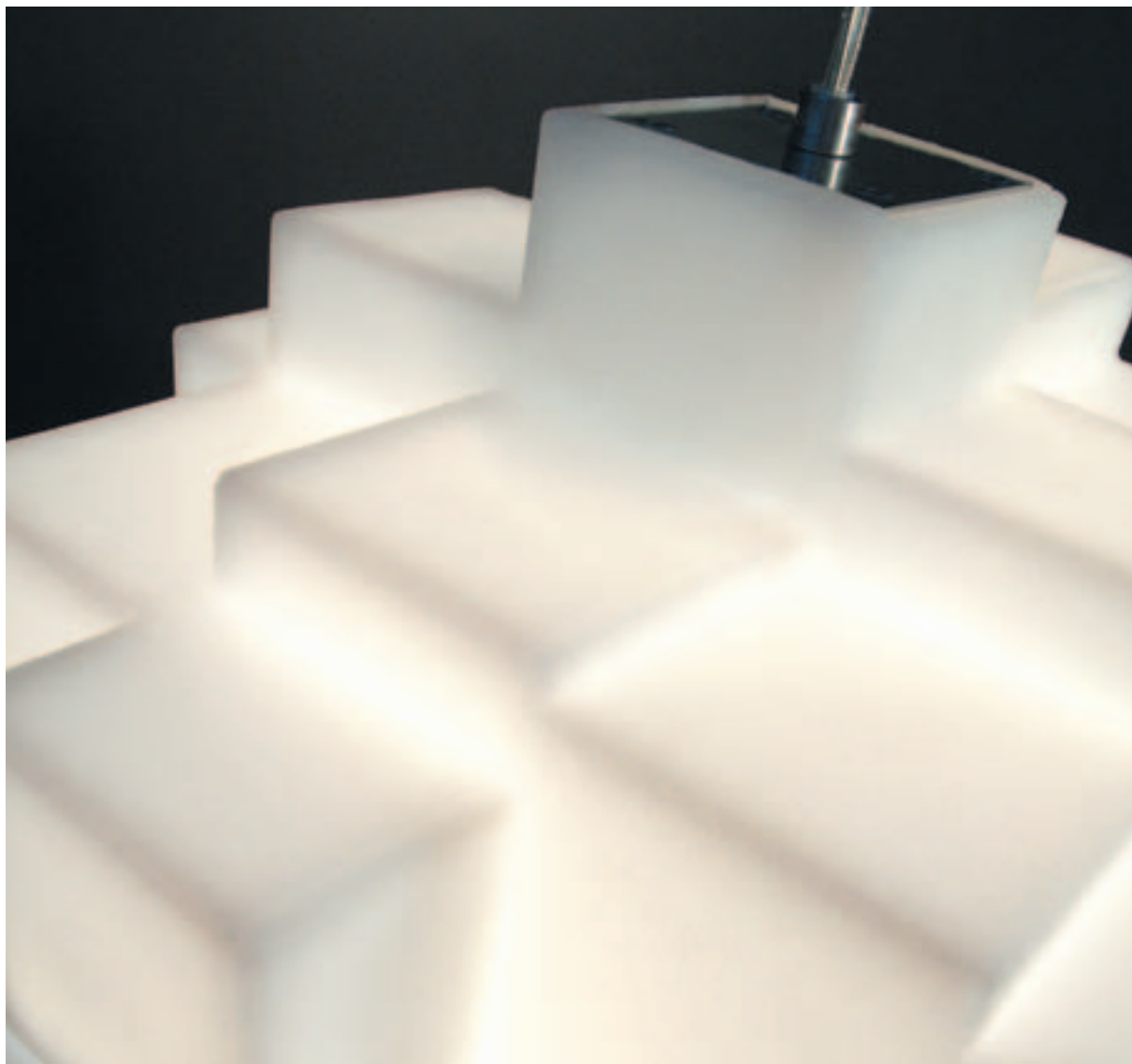

Metropolis

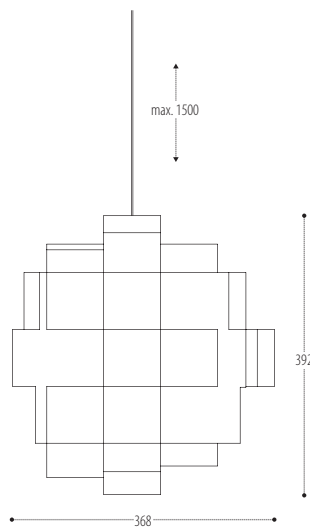

BODY

 Transparent white

 PE | Metal

 1x A60 (MAX 60 W) / E27

 1x QA60 (MAX 42 W) / E27

 1x TCA-SE (MAX 11 W) / E27

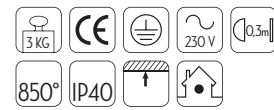

METROPOLIS

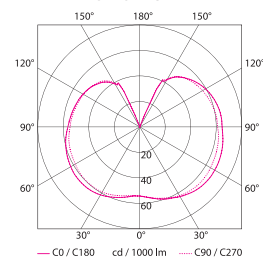

Efficiency factor: 71,5%

NO COPY

design Anthony Duffeleer for Dark



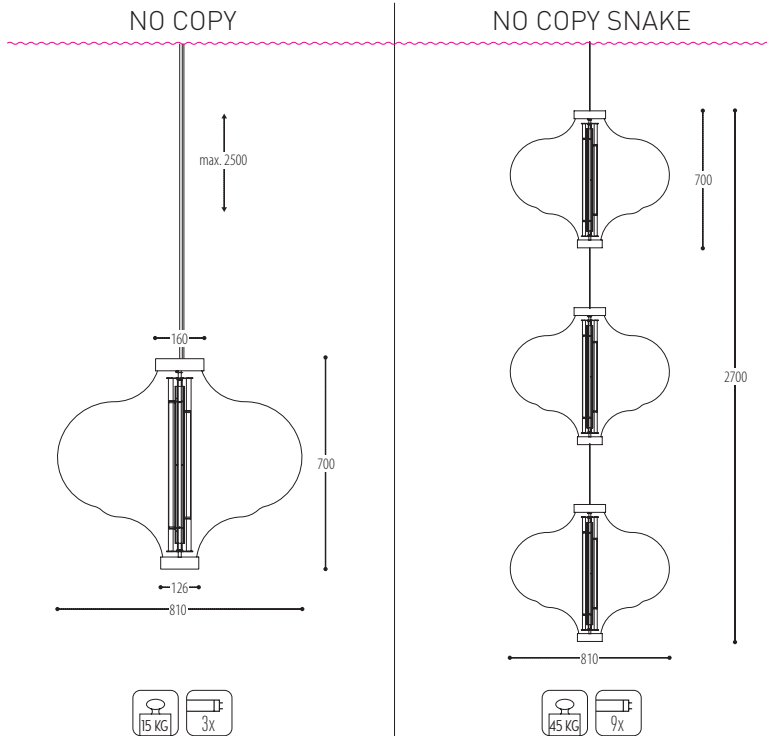

BODY

 Transparant white

WITH COLOURED BULBS

 Red  Blue  Green

On request other colours possible with colourfilters

PE | Metal

 T16 (14 W) / G5

 T16 (24 W) / G5

LED

    850° 

NO COPY 3x24W

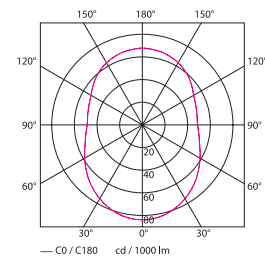

Efficiency factor: 72.8%

PROJECT PAGES:

015 - 017 - 052 - 139 - 149 - 156 - 184

NO FRUIT

design Anthony Duffeleer for Dark



DESIGN **PLUS**
2004





NO FRUIT - fix colour with colour bulbs or changing colours with LED-technology

NO FRUIT

TECHNICAL SHEET

131

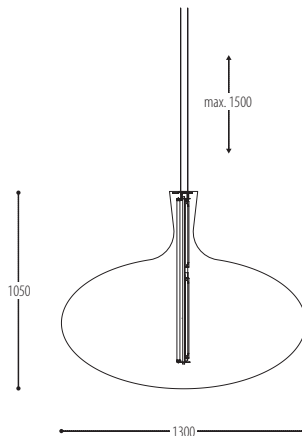

BODY

 Transparant white

WITH COLOURED BULBS

 Red  Blue  Green

On request other colours possible with colourfilters

 PE  Metal

 3x T16 (21 W) / G5

 3x T16 (39 W) / G5

 LED

     850° 

NO FRUIT 3x39W

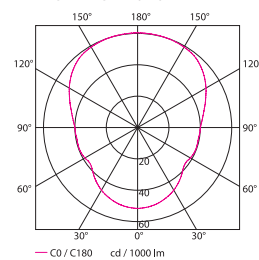

Efficiency factor: 57,5%

PROJECT PAGES:

002 - 012 - 015 - 017 - 023 - 084 - 096 -
099 - 115 - 116 - 125 - 145 - 172 - 181 -
187

NO FRUIT bling bling

designed for the celebration of 5 years Dark





BODY

 960 Swarovski stones

Swarovski	Metal
-----------	-------

 3x T16 (21 W) / G5

 3x T16 (39 W) / G5

 LED



OBLIVION

design Arne Quinze for Dark



USA 2006



OBLIVION 3xT16 (21W)



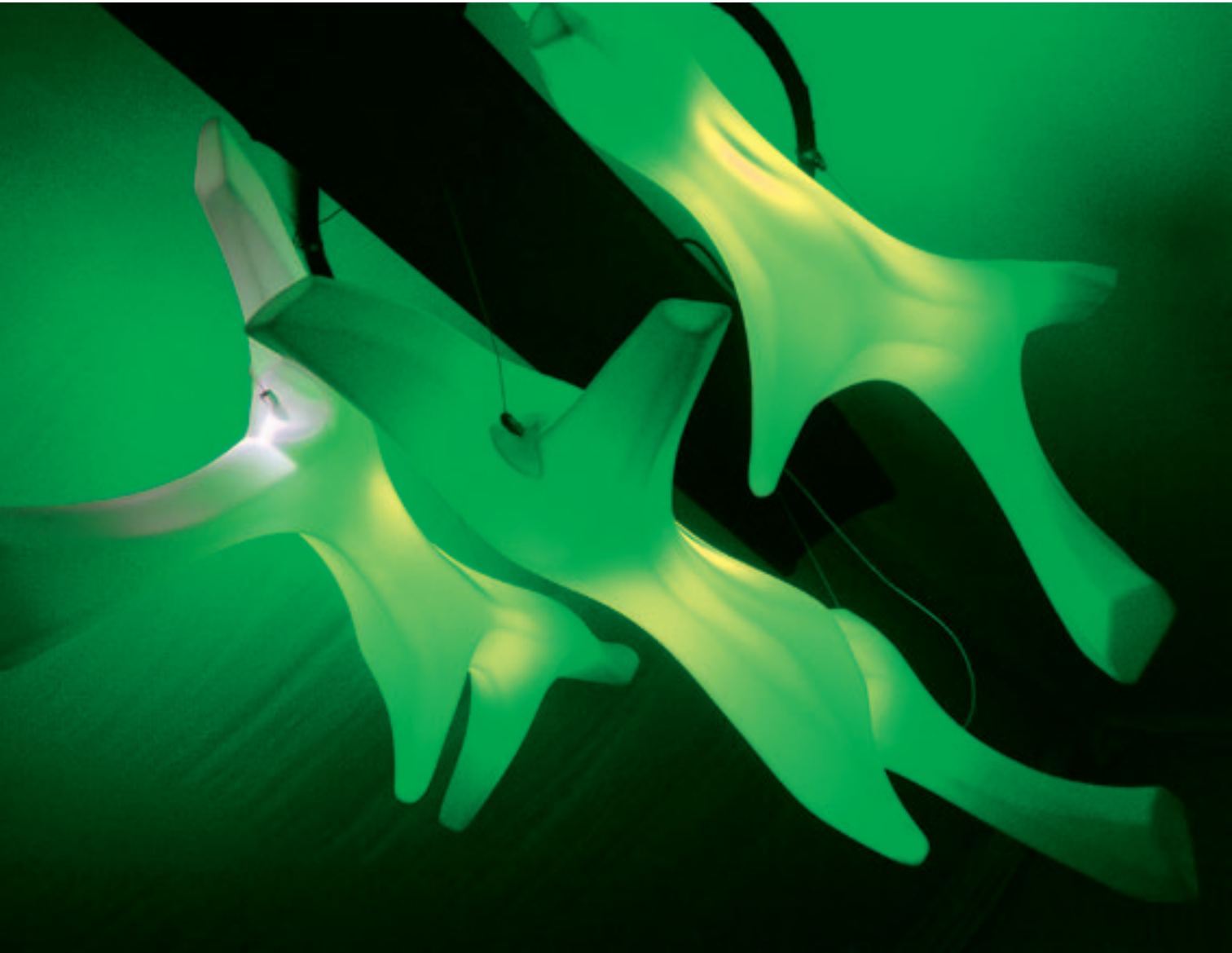

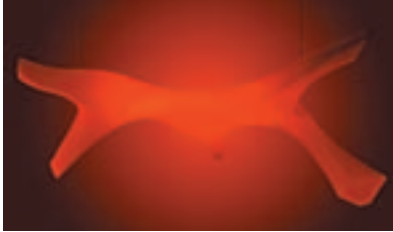

OBLIVION red bulbs



OBLIVION blue bulbs

BODY



WITH COLOURED BULBS



On request other colours possible with colourfilters



OBLIVION 3x21W

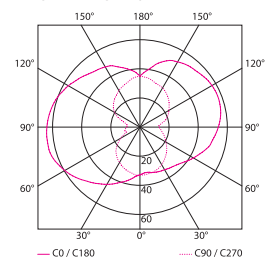

Efficiency factor: 48,8%

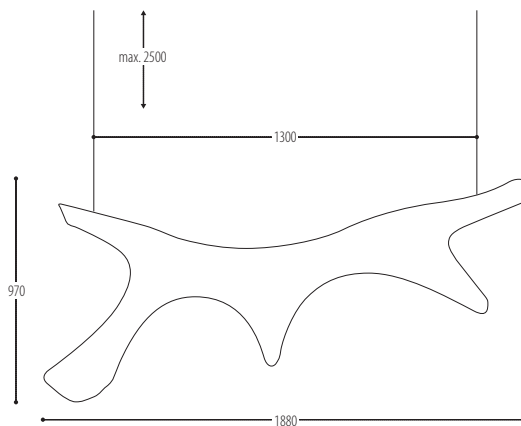

PROJECT PAGES:

009 - 041 - 052 - 103 - 105 - 122 - 136 - 166

PANTY

design Sem de l'Anverre &
Kris Henkens for Dark







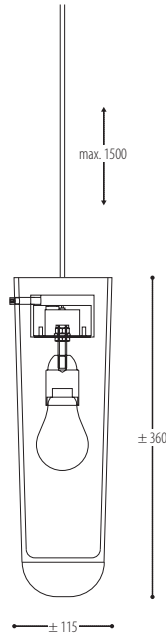
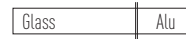
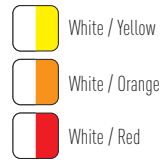

PANTY
white / yellow

PANTY
white / orange

PANTY
white / red



-  1x A60 (MAX 60 W) / E27
-  1x OA60 (MAX 42 W) / E27
-  1x TCA-SE (MAX 11 W) / E27
-  1x LED (MAX 7 W) / E27



PAROQ

design Oldsjö Hultgren for Dark



USA 2008

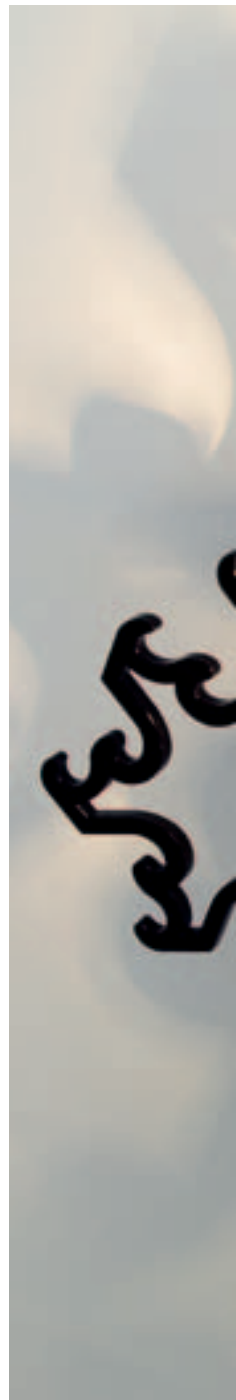





PAROQ 3 white - silver bulbs

PAROQ 1

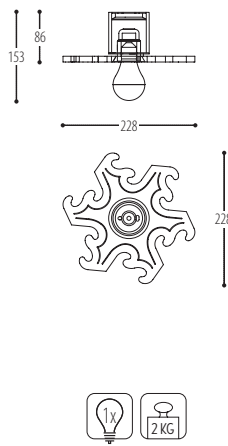

PAROQ 2

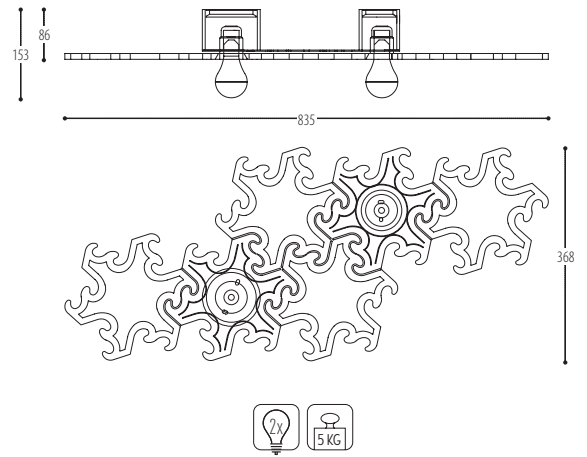

PAROQ 3

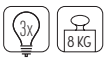
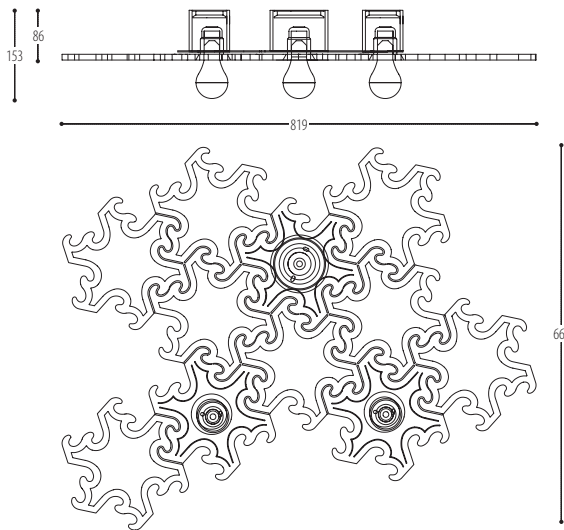

SILVER BULB



GOLDEN BULB



PAWWW

design Christophe De Ryck for Dark



reddot design award
winner 2009

PAWWW white

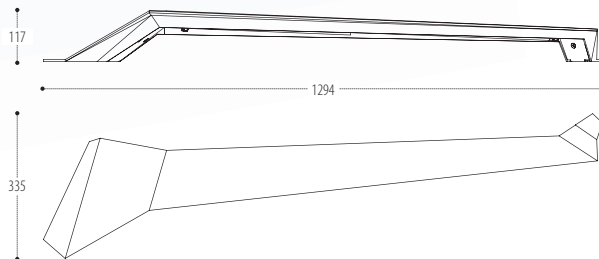

White



Black



On request

Alu



2x T16 (21 W) / G5



2x T16 (39 W) / G5



PAWWW WHITE 2x39W

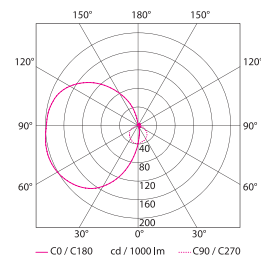

Efficiency factor: 67,6%

POC

design Johanna Lindgren & Helen Högberg for Dark



DESIGN PLUS
2006



POC - white fabrics

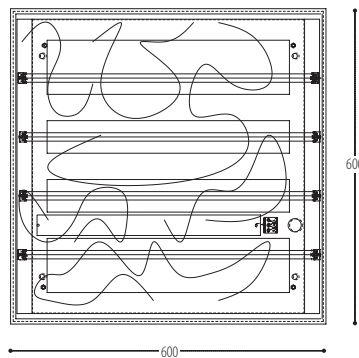
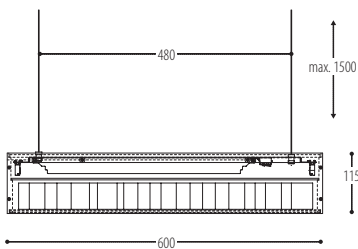

BODY



FILLING

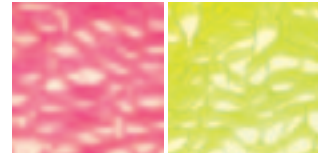

fluo red strings

fluo green strings

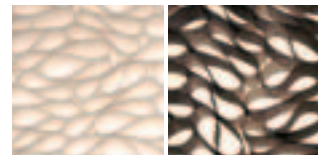

white fabrics

silver fabrics



POC 4x14W

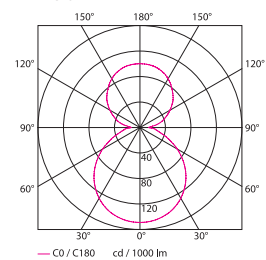

Efficiency factor: 80,5%

PROJECT PAGES:

069 - 093 - 095 - 113 - 146 - 150 - 151 - 190

ROSET

design Frederike Top for Dark





ROSET white
silver bulb



ROSET alu
silver bulb



ROSET black
golden bulb

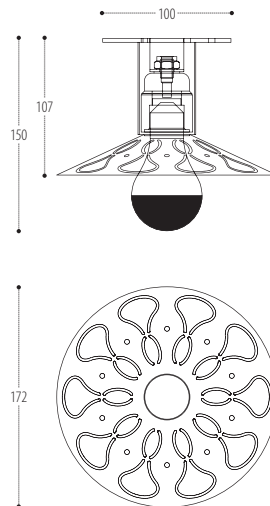

White



Black



Alu



On request

Metal

SILVER BULB



A60-CS-G (MAX 60 W) / E27



TCA 60-CS/G (MAX 7 W) / E27

GOLDEN BULB



A60-CS-G (MAX 60 W) / E27



TCA 60-CS/G (MAX 7 W) / E27



PROJECT PAGES:

061

150

R&S

design JP Meulendijks for Dark





R&S black

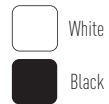
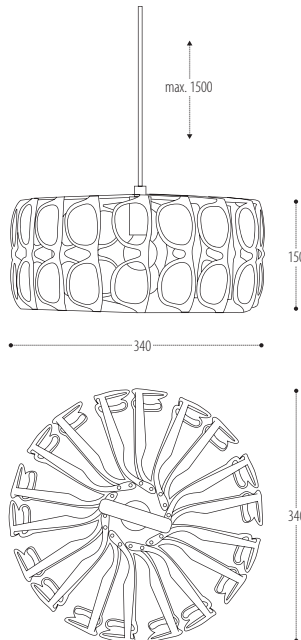

-  1x D45 (MAX 60 W) / E14
-  1x OD45 (MAX 42 W) / E14
-  1x TCA-SE (MAX 7 W) / E14



PROJECT PAGES:

111

SLITE

design Karen & Vince for Dark

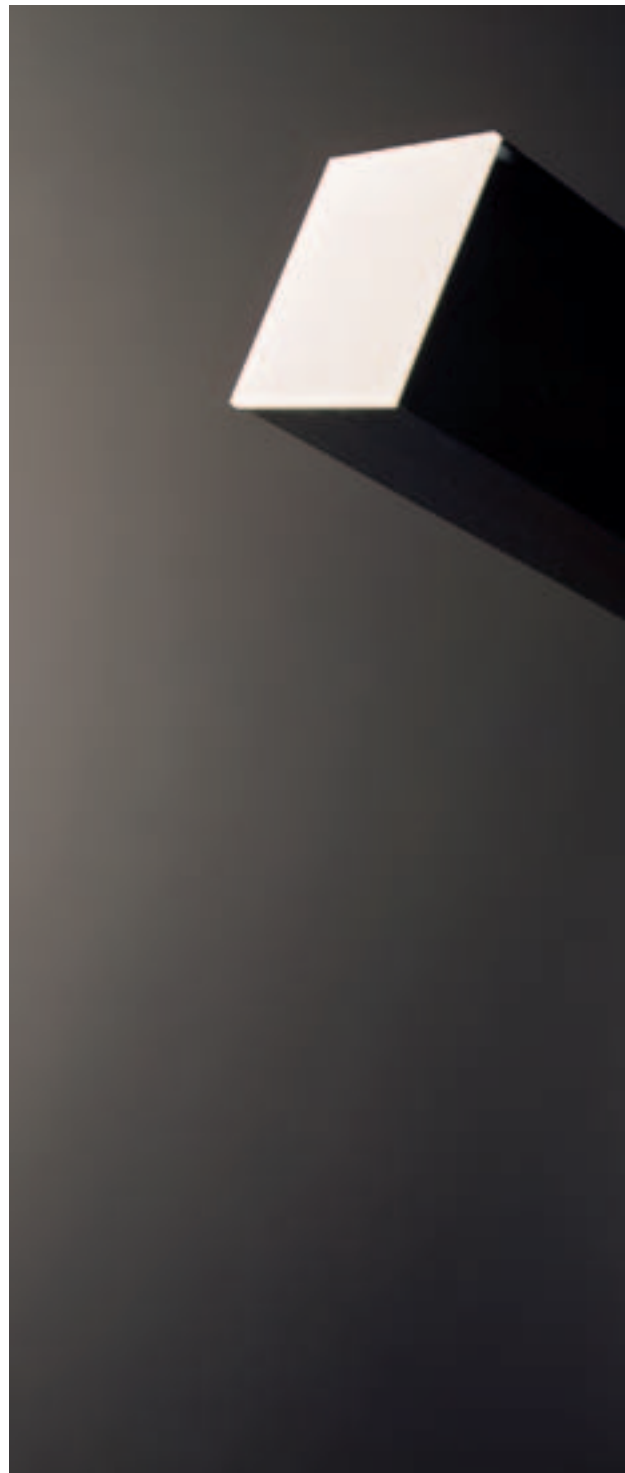



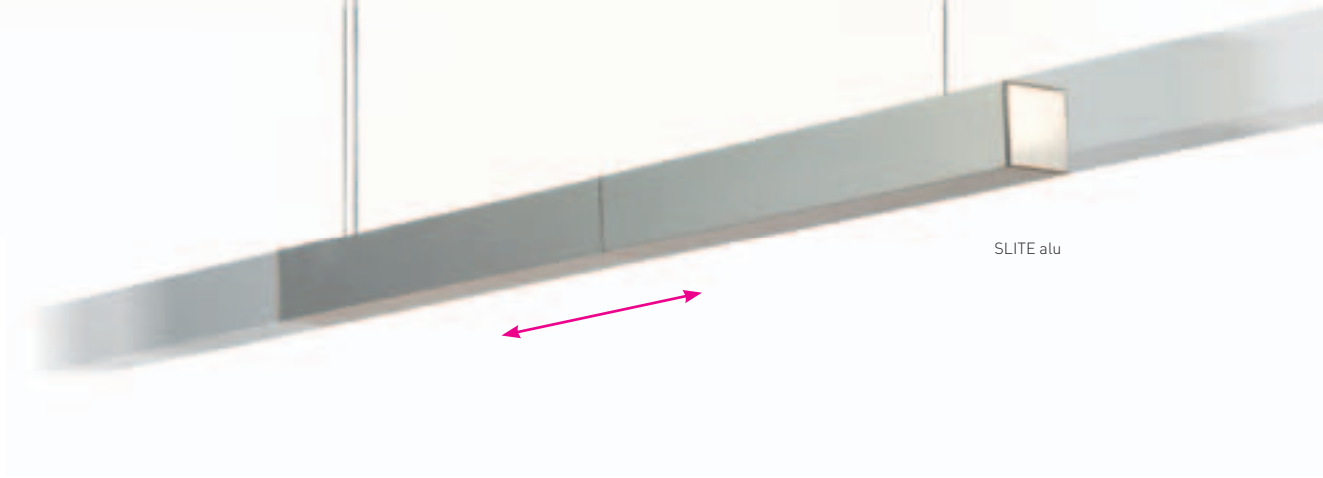

SLITE alu



SLITE

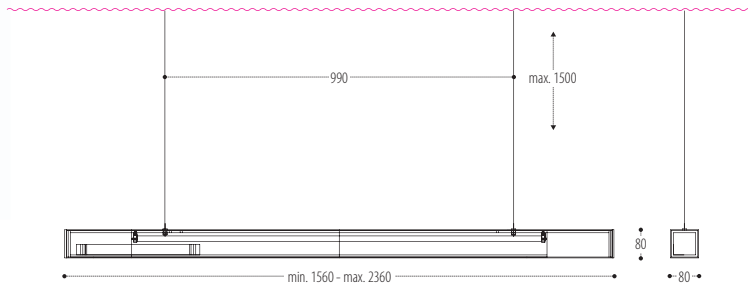

SLITE WALL

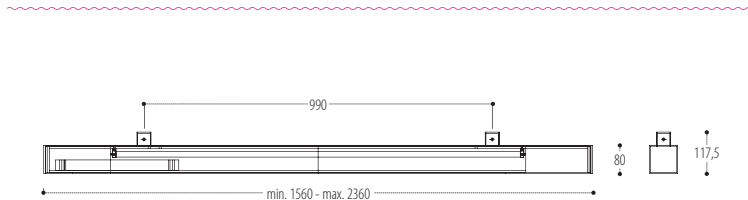

- White
- Black
- Alu

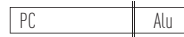

- 1x T16 (28 W) / G5
- 1x T16 (54 W) / G5

-
-
-
-
-
-
-
-
-
-
-
-

SLITE S

SLITE WALL

SLITE 1x54W

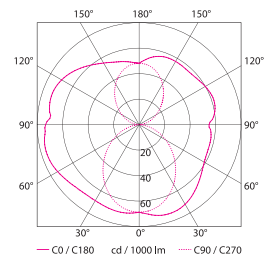

Efficiency factor: 57,1%

SNOWDOME

design Maximal Design for Dark

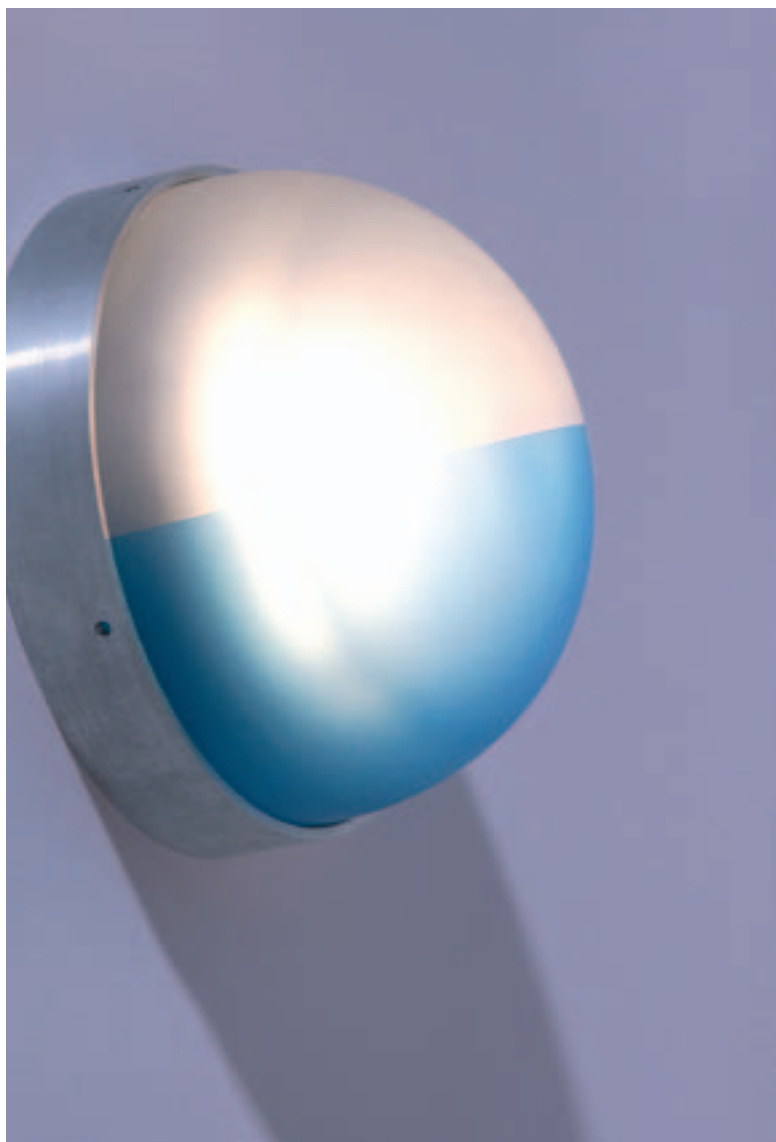

SNOWDOME glass white/blue



SNOWDOME
glass white





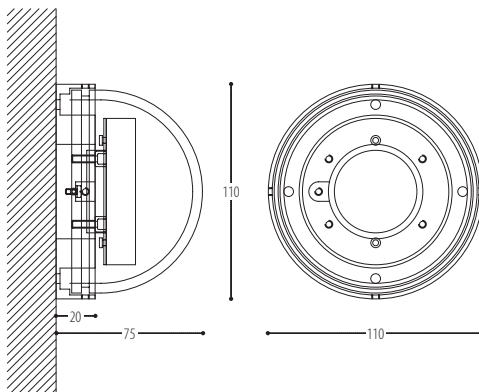

SNOWDOME
glass white/blue

SNOWDOME
glass white/red

SNOWDOME
glass white/green



GLASSES

-  White
-  White / Red
-  White / Blue
-  White / Green

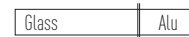

 1x MICRO-LYNX F (6 W) / GX53

 1x MICRO-LYNX LED (1,5 W) / GX53
Colours : Cool white / Red / Green / Blue / Yellow



SNOWDOME WHITE

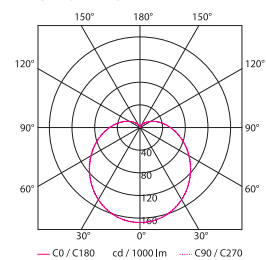

Efficiency factor: 79,8%

SON OF EDDY

design Davy Grosemans for Dark

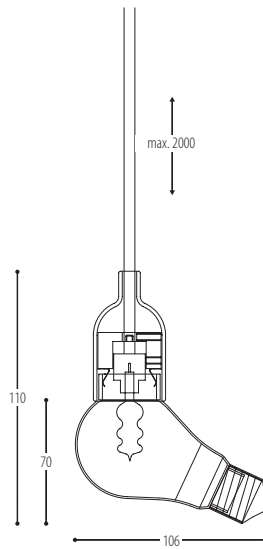



- White
- Black

Glass | Silicone

 1x QT14 (MAX 40 W) / G9



SON OF EDDY

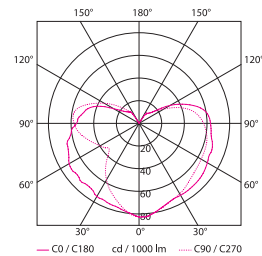

Efficiency factor: 57,8%

SPACEWALKER

design Constantin Wortmann for Dark

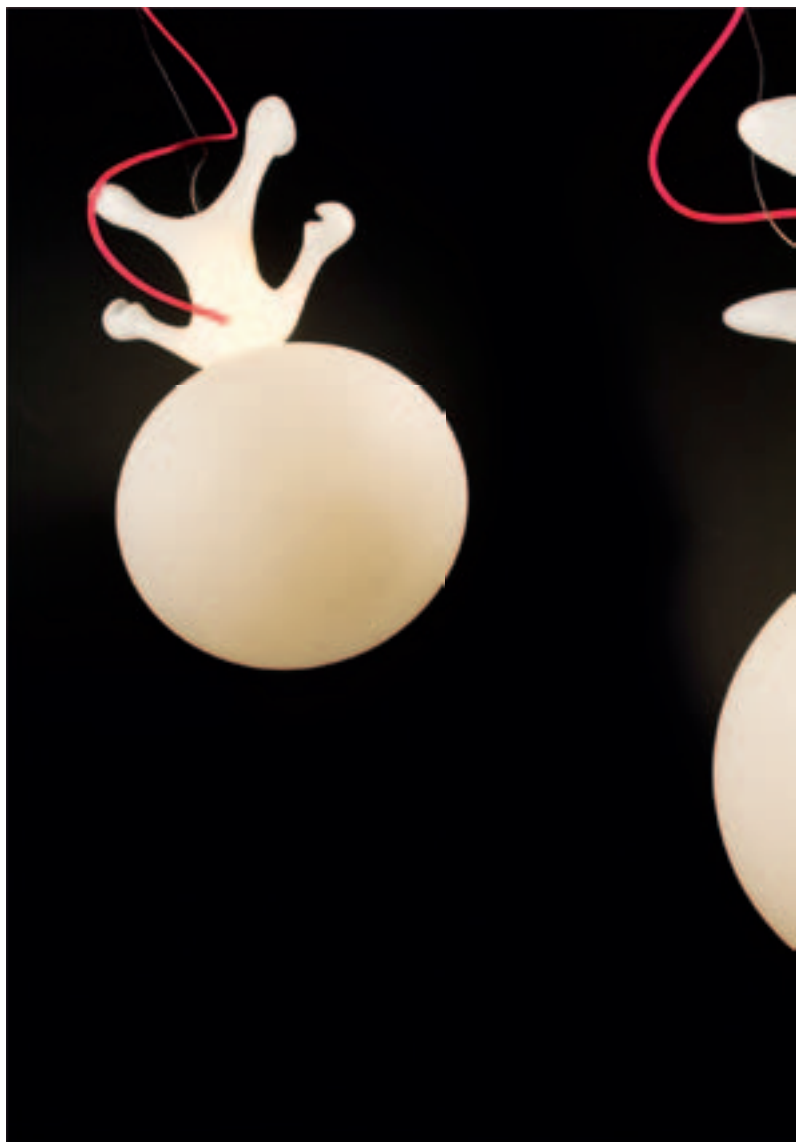

SPACEWALKER S 3 x 39W

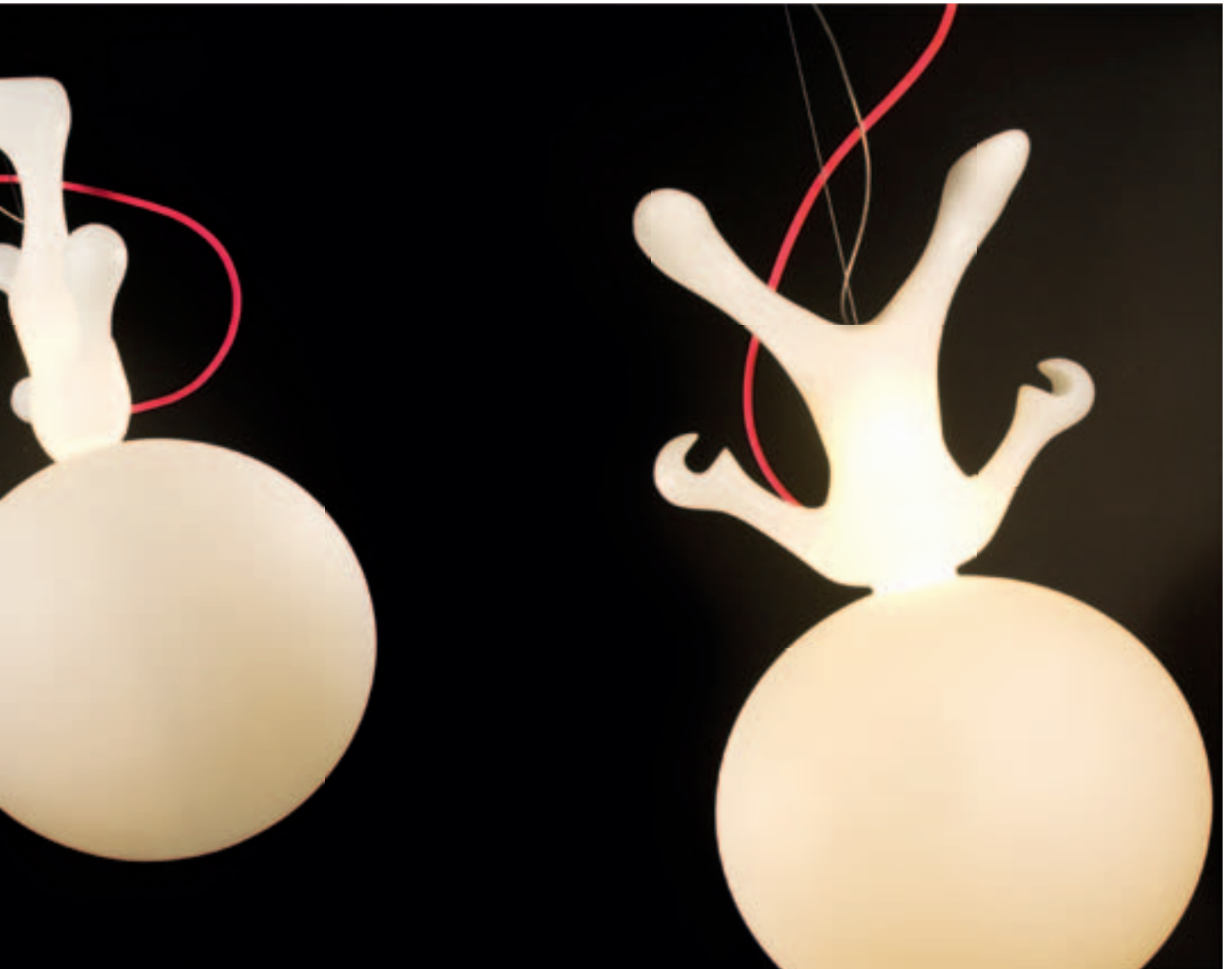



SPACEWALKER

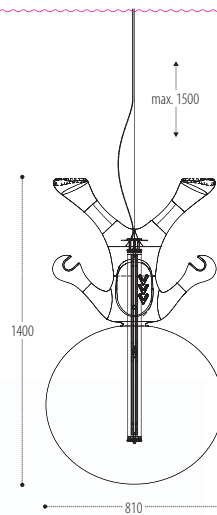

SPACEWALKER FLOOR

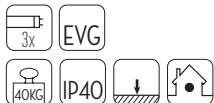
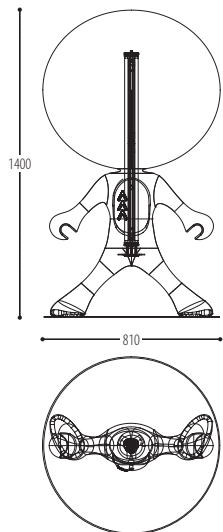

SPACEWALKER FLOOR EXTERIOR

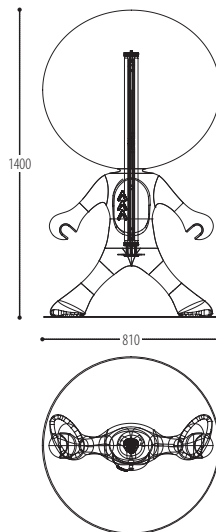

BODY



WITH COLOURED BULBS



On request other colours possible with colourfilters

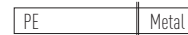

PROJECT PAGES:

039 - 117 - 174 - 175 - 181



SPACEWALKER JR. / S



SPACEWALKER JR.

SPACEWALKER JR.

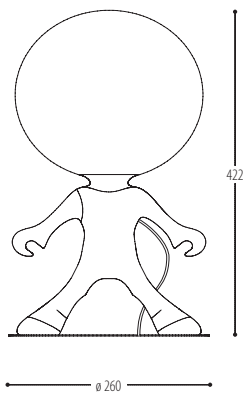

SPACEWALKER JR. / S

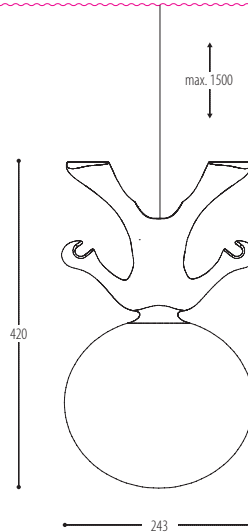

BODY

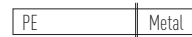

166

SPINE

design Pieterjan for Dark





SPINE white - up black



SPINE white - up red

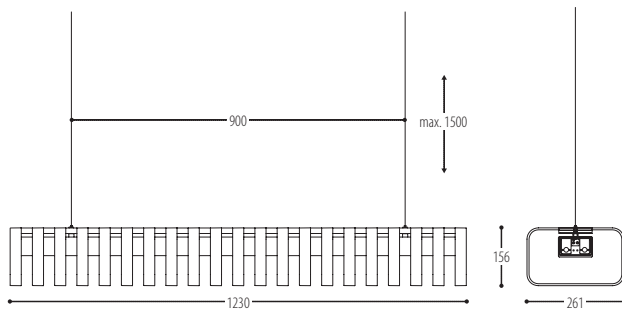

BODY



White



Black

UP DETAIL



Clear



Black



Fluo red

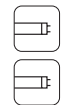

2x T16 (28 W) / G5



2x T16 (54 W) / G5



SPINE WHITE 2x28W

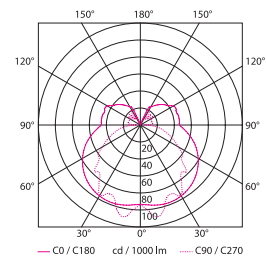

Efficiency factor: 66,1%

STAR '58

creatie Lucien de Roeck
design Luc Vincent for Dark



Star '58

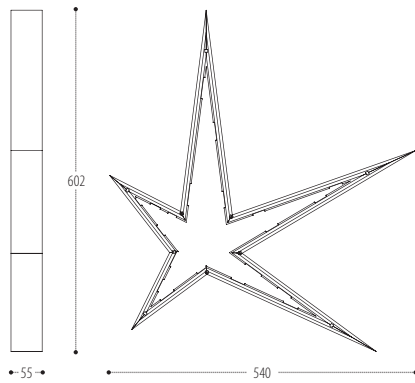

SQUARE ANGEL

design Luc Vincent for Dark



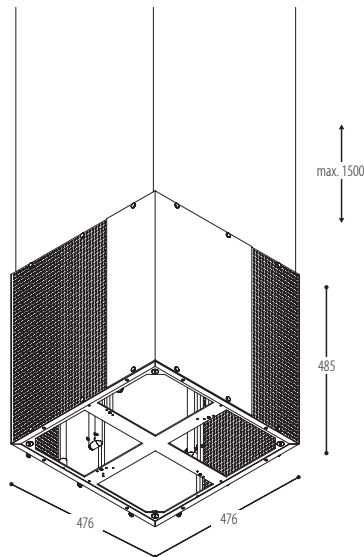

BODY



White



Black

FROSTED PLEXI



Orange



Yellow



Red



Pink



Blue



4x TC-L (36W) / 2611



PROJECT PAGES:

161 - 162

TRAPPED

design Sem de l'Anverre & Kris Henkens for Dark



DESIGNPREIS
2009
NOMINIERT



USA 2007

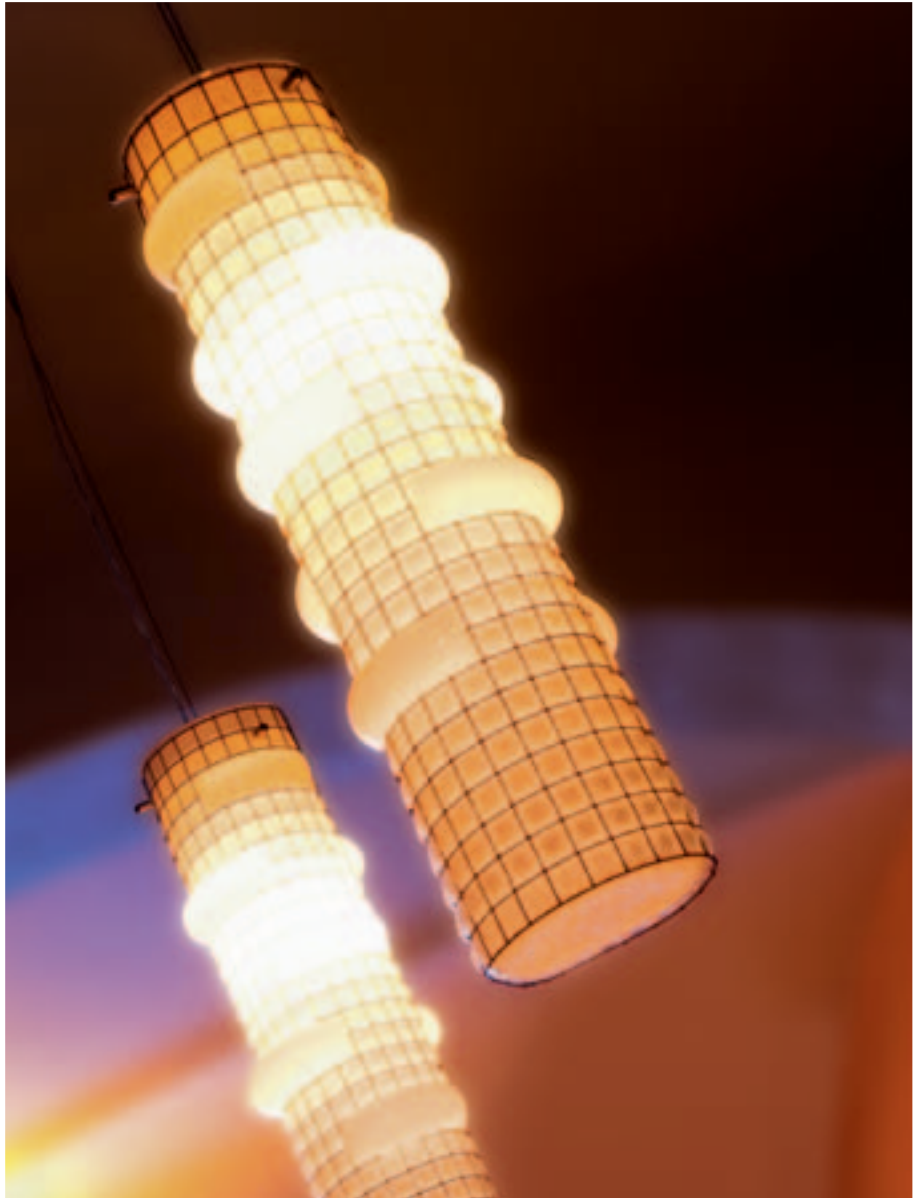

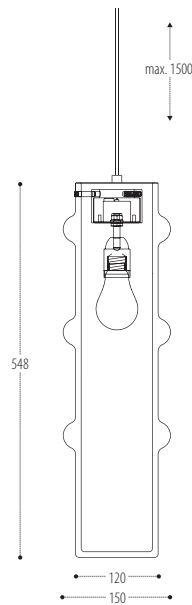
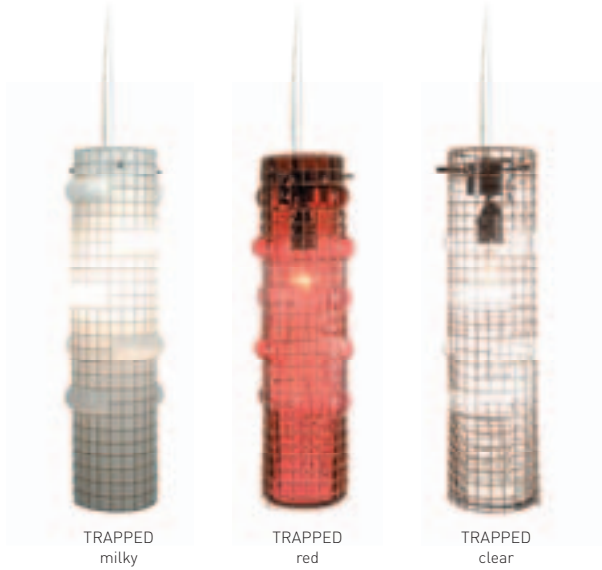

TRAPPED milky



- Milky
- Red
- Clear



-  1x A60 (MAX 100 W) / E27
-  1x TCA-SE (MAX 15 W) / E27
-  1x LED (MAX 7 W) / E27



















PROJECT PAGES:
058 - 172 - 173 - 187

176

T&T

design Christophe De Ryck for Dark



reddot design award
winner 2009



T&T white

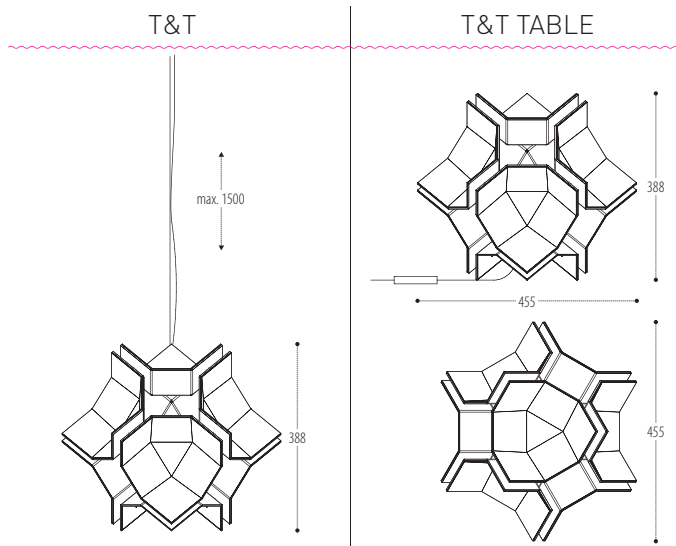
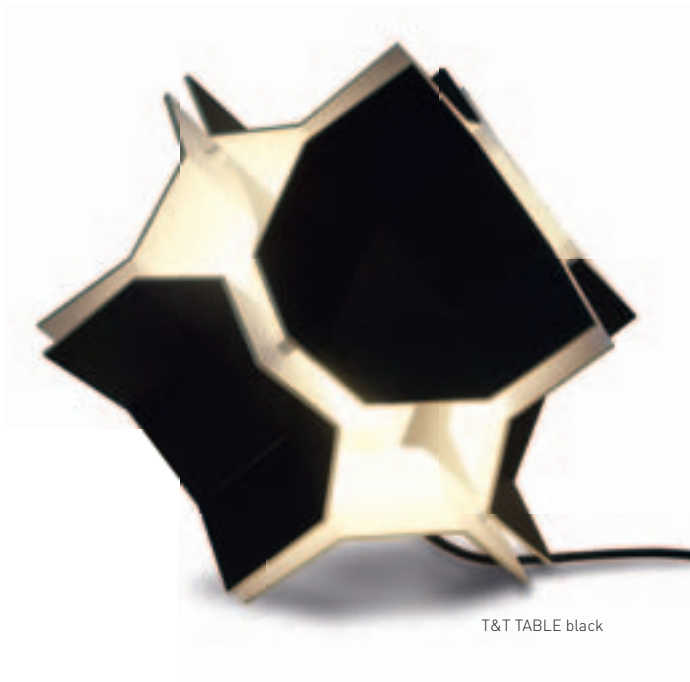

T&T 1xTCG-SE 15W

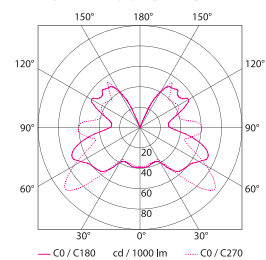

Efficiency factor: 61,1%

TSJOEPY

design Anthony Duffeleer for Dark





TSJOEPLY
white glossy



TSJOEPLY
red glossy



TSJOEPLY
black glossy

- White glossy
- Black glossy
- Red glossy



Polyester | Metal

- 1x QPAR20 (MAX 50 W) / E27
- 1x HIPAR20 (35 W) / E27
- 0.5m
- 0.9m
- EVG
- INCL GEAR

TSJOEPLY S

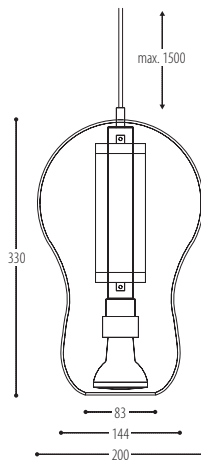

TSJOEPLY R

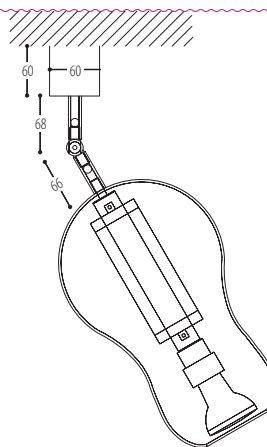

- 3 KG
-
-
- 230 V
- 96°
- IP40
-
-
- TSJOEPLY S
- TSJOEPLY R

QPAR20 45W-22°

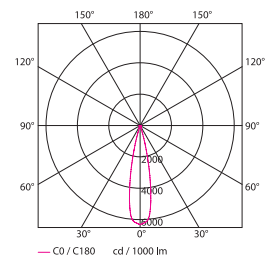

Efficiency factor: 100%

PROJECT PAGES:

024 - 042 - 051 - 087 - 106 - 124 - 185 - 186

180

TWOLVE

design Christophe De Ryck for Dark



reddot design award
winner 2009

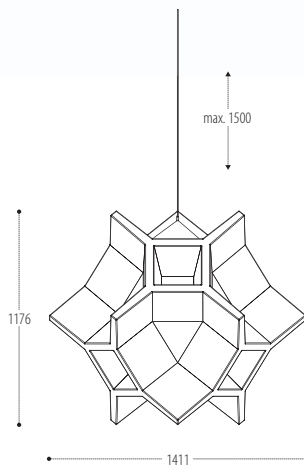

BODY

Transparant white

WITH COLOURED BULBS

Red Blue Green

On request other colours possible with colourfilters

PE | Metal

- 3x T16 (24 W) / G5
- EVG
- EVGD
- DALI
- INCL GEAR
- 6x T16 (24 W) / G5
- EVG
- EVGD
- DALI
- INCL GEAR
- LED

- 25 KG
- CE
- 230 V
- 0.2m
- 850°
- IP20
- PV
- TWOLVE
- TWOLVE FLOOR

182

YOKOZUNA

design Fabien Dumas for Dark





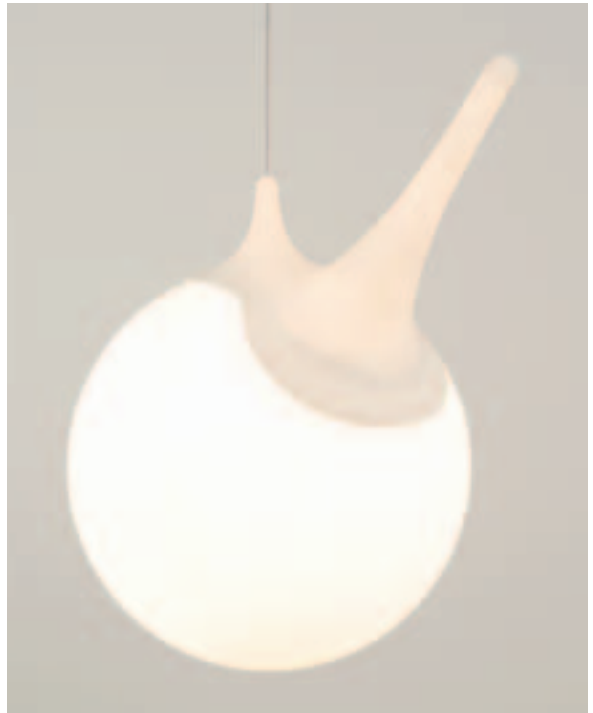
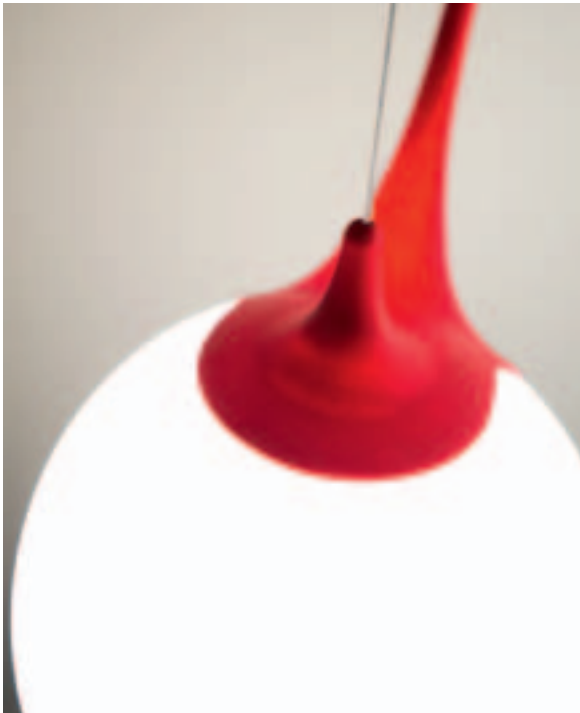
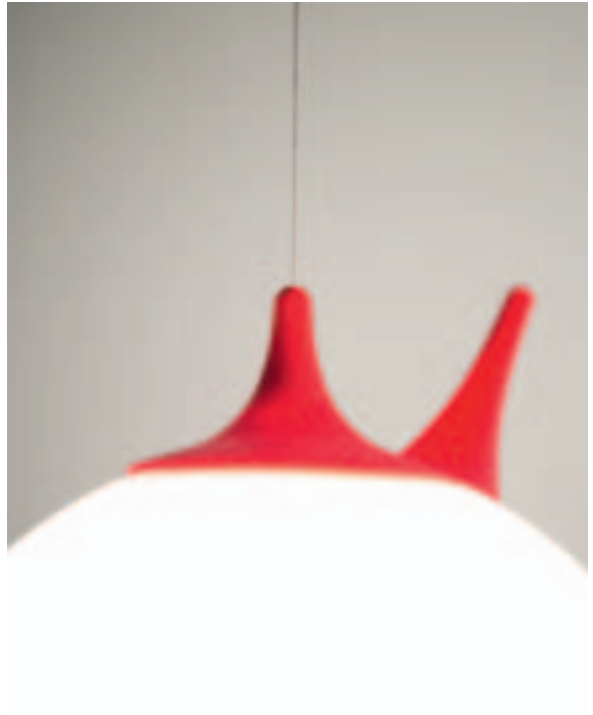

YOKOZUNA JR. white / red

YOKOZUNA JR. white / white

YOKOZUNA

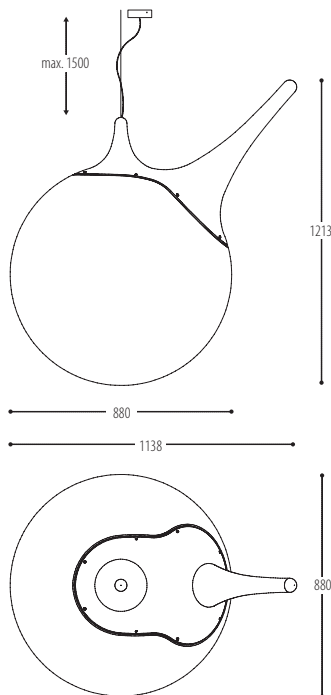

YOKOZUNA JR.

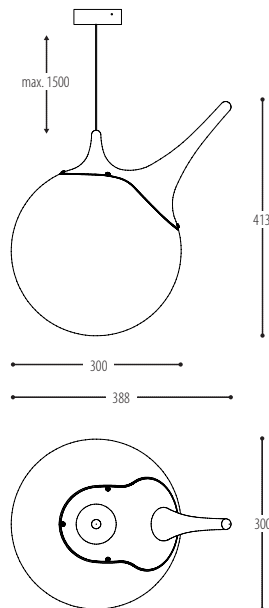

BODY

-  Transpartant white / white
-  Transpartant white / red

WITH COLOURED BULBS

-  Red
-  Blue
-  Green

On request other colours possible with colourfilters

PE	Metal
----	-------

YOKOZUNA

 3x T16 (24 W) / G5

 LED

YOKOZUNA JR.

 1x A60 (MAX 60 W) / E27

 1x QA60 (MAX 42 W) / E27

 1x TC-TSE (MAX 11 W) / E27

 1x LED (MAX 7 W) / E27

 5 KG  0.5m

PROJECT PAGES:

182

ZUPER

design Frank Janssens for Dark



ZUPER SQUARE black

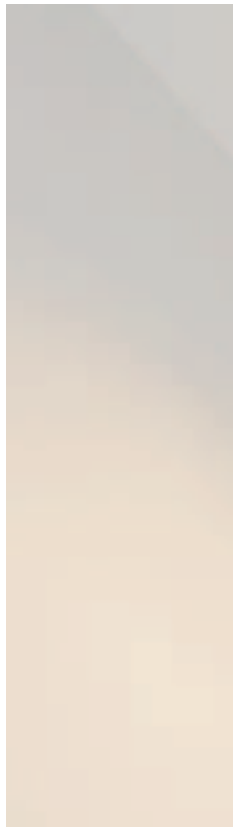

ZUPER ROUND white





ZUPER ROUND black



ZUPER ROUND Ø190 white with opale glass



ZUPER ROUND Ø190 white

ZUPER ROUND Ø170

CUT OUT
Ø152

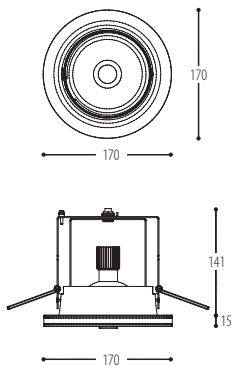

ZUPER ROUND Ø190

CUT OUT
Ø168

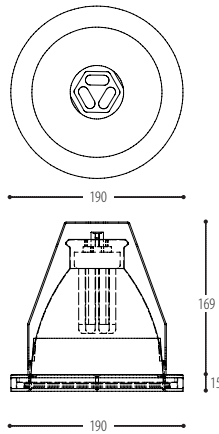

ZUPER ROUND Ø190

CUT OUT
Ø168

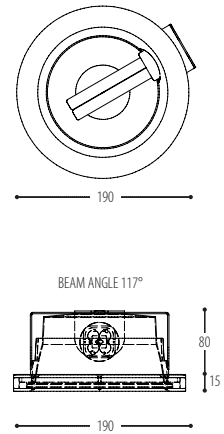

ZUPER ROUND

TECHNICAL SHEET

189



ZUPER ROUND Ø190 black

ZUPER ROUND Ø170

IP20	12 V	EXCL TRANSFO	1x QR-LP111 (MAX 45 W) / G53
	230 V	EXCL GEAR	1x HIR-CE111 (35 W) / GX8.5 1x HIR-CE111 (70 W) / GX8.5
IP66	0.7m	EXCL GEAR	1x HIT-TC-CE (35 W) / G8.5 1x HIT-TC-CE (70 W) / G8.5
	LED	led reflector	must be used with 14° 24° 36° 54° 20° 40° 60°
Colour temp 2700K / 3000K / 4000K -->			700 Lm >80 CRI 700 mA --> 16W
Colour temp 2700K / 3000K / 4000K -->			1000 Lm >80 CRI 700 mA --> 23W
Colour temp 2700K / 3000K / 4000K -->			700 Lm >95 CRI 700 mA --> 23W

ZUPER ROUND Ø190

IP20	230 V	INCL/EXCL GEAR	1x TC-DEL (13 W) / G24q-1	IP44 OPTION + glass CLEAR OPALE
			1x TC-TEL (18 W) / GX24q-2	



HIR-CE111 35W - 21°

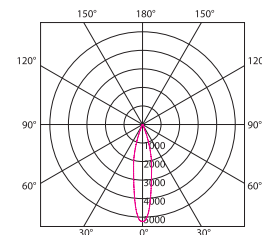

Efficiency factor: 100%

QR-LP111 45W-22°

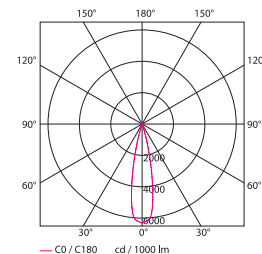

Efficiency factor: 100%



ZUPER SQUARE white

ZUPER SQUARE

CUT OUT 145x145 mm

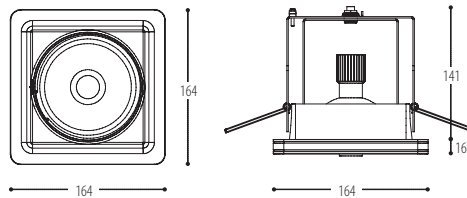

ZUPER SQUARE

IP20 EXCL TRANSFO	 EXCL GEAR	1x QR-LP111 (MAX 45 W) / G53
		1x HIR-CE111 (35 W) / GX8,5 1x HIR-CE111 (70 W) / GX8,5 1x HIT-TC-CE (35 W) / G8,5 1x HIT-TC-CE (70 W) / G8,5
IP66 EXCL GEAR	LED	must be used with
		led reflector
		Colour temp 2700K / 3000K / 4000K --> >80 CRI --> 16W Colour temp 2700K / 3000K / 4000K --> >80 CRI --> 23W Colour temp 2700K / 3000K / 4000K --> >95 CRI --> 23W



HIR-CE111 35W - 21°

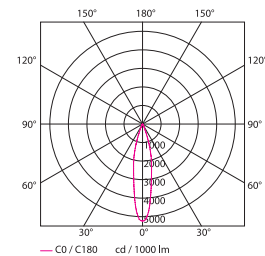

Efficiency factor: 100%

QR-LP111 45W-22°

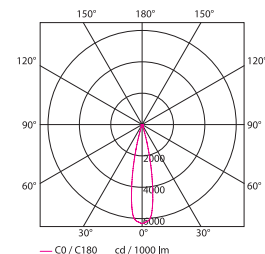

Efficiency factor: 100%

PROJECTS

NO FRUIT _ METROPOLIS

Project: Gran Hotel Sol y Mar, Calpe - Spain
Interiorarchitect: Xavier Pastor







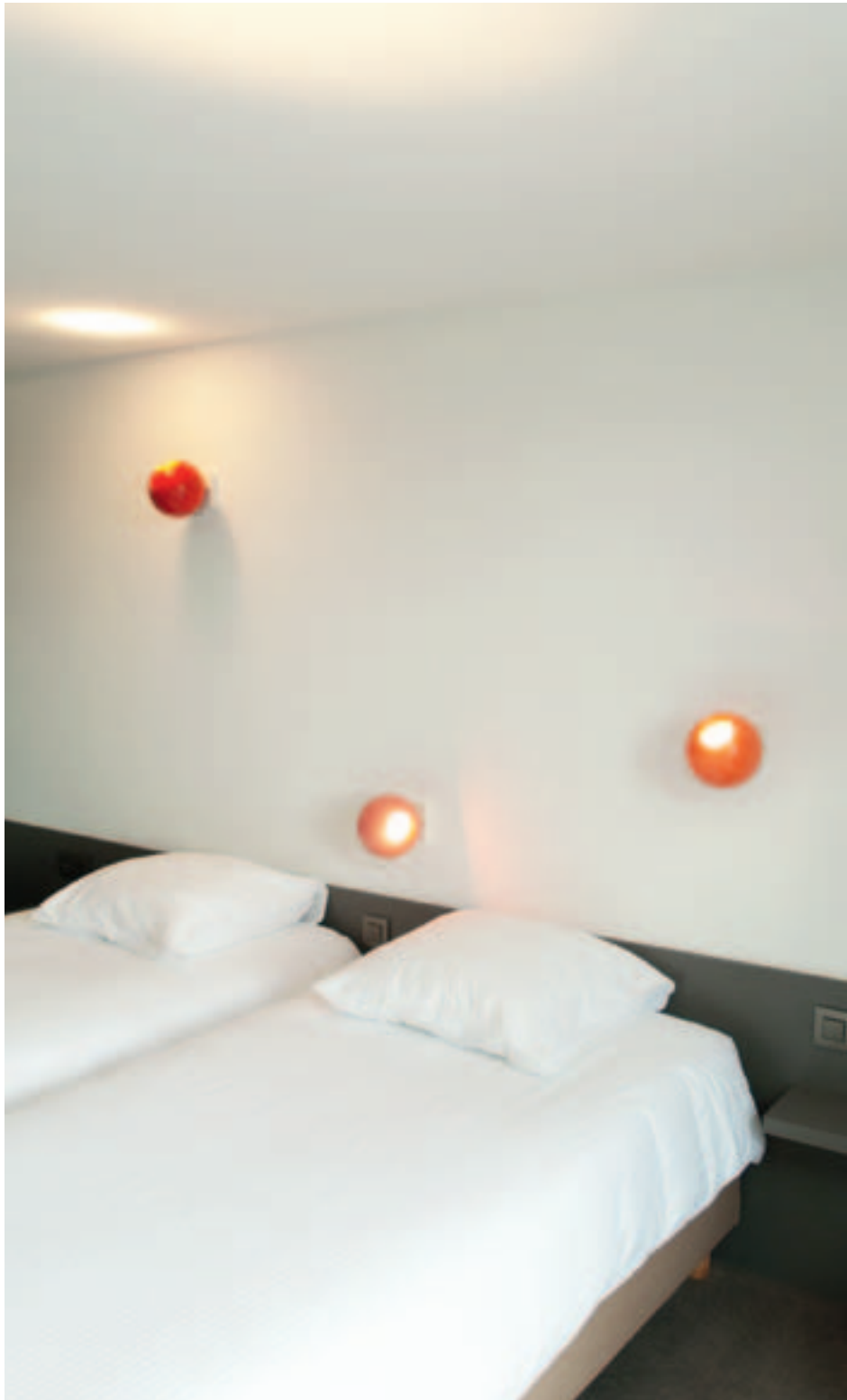

12-25

Project: Corbie Hotel, Geel
Concept: Nelva

12-25

Project: Corbie Hotel, Geel
Concept: Nelva









12-25

Project: Acta - Bommel

Architect: IngeClaudia

d-CONCRETE

Project: Kant, Brugge

Architect: Ivan Missinne for E&L projects

OBLIVION

Project: Novotel, Amsterdam, The Netherlands

Concept: Proof Consultancy

TWOLVE

Project: Habbekrats, Kortrijk

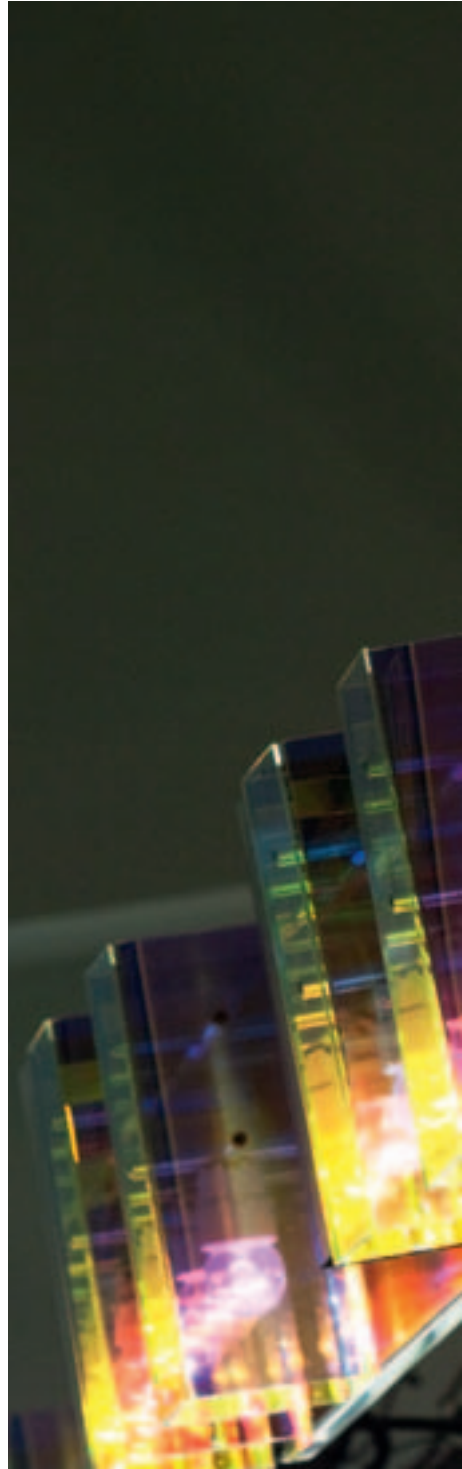

BRIDGE

Project: Restaurant Il Mercato, Lens
Concept: Michel Pirritano, Nuances, Lens
Assistance: Prolum, Reims



NO FRUIT

Project: Exki, Brussel

D2V2 FLOOR

Project: Duravit Event

ICE

Project: Stadshaven, Rotterdam

Architect: Fabrique







NO FRUIT _ NO COPY

Project: C/C Cité Europe - Coquelles

Concept: Bruno Gerome, Carré Noir, Paris

Realisation: AU4G Architecture, Paris pour Unibail





NO FRUIT _ NO COPY

Project: C/C Citée Europe - Coquelles
Concept: Bruno Gerome, Carré Noir, Paris
Realisation: AU4G Architecture, Paris pour Unibail



APOLLO

Jazz festival, Montreux

LGTM-X01

Light and Building, Frankfurt

CHUBBY BOX

Interieur 2008

SPINE

Interieur 2008





BRIDGE TWO

Project: Restaurant Griotte, Paris







BRIDGE TWO _ NO FRUIT
Project: Restaurant Griotte, Paris





HOPPY _ TSJOEPY

Project: Levro, Breskens
Architect: Lieven Musschoot



D2V2

Project: l'Escale, Le Touquet

Concept et réalisation: Dogsign Architecture, Lille

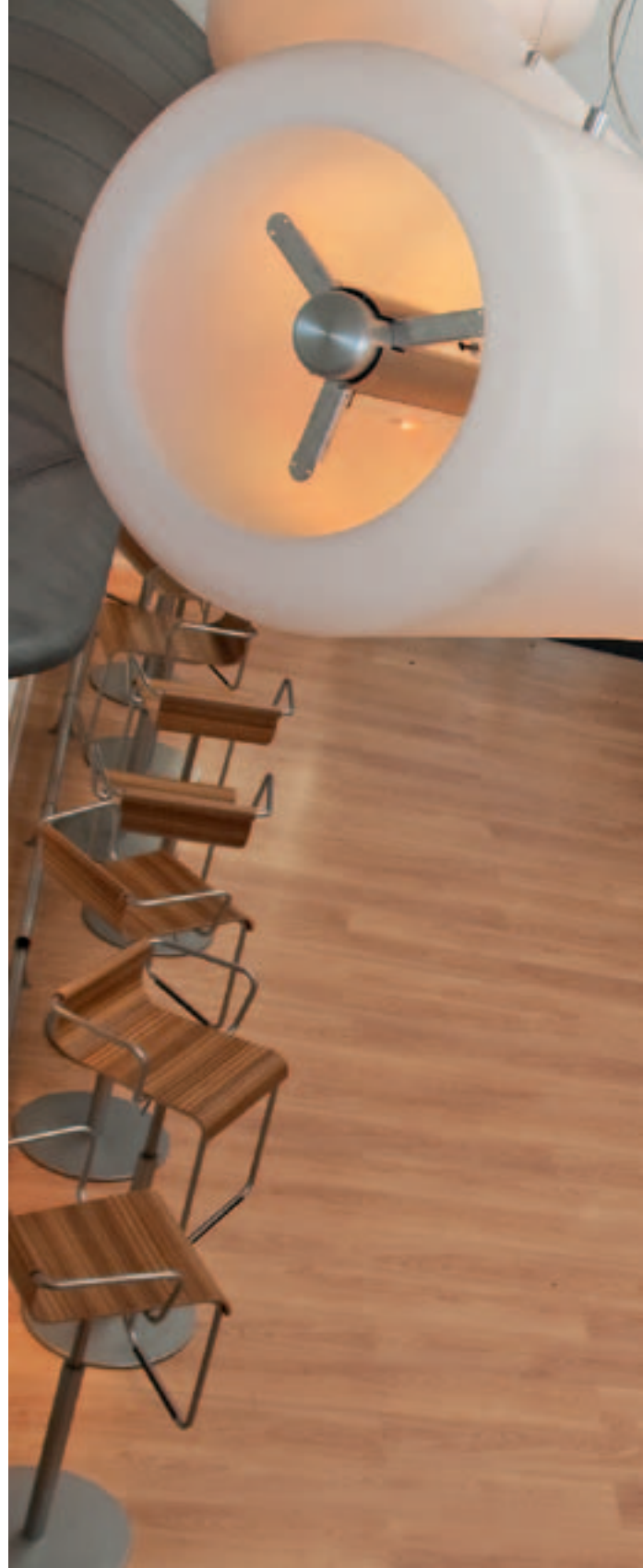



D2V2 _ 12-25 _ PAWWW

Project: l'Escale, Le Touquet

Concept et réalisation: Dogsign Architecture, Lille





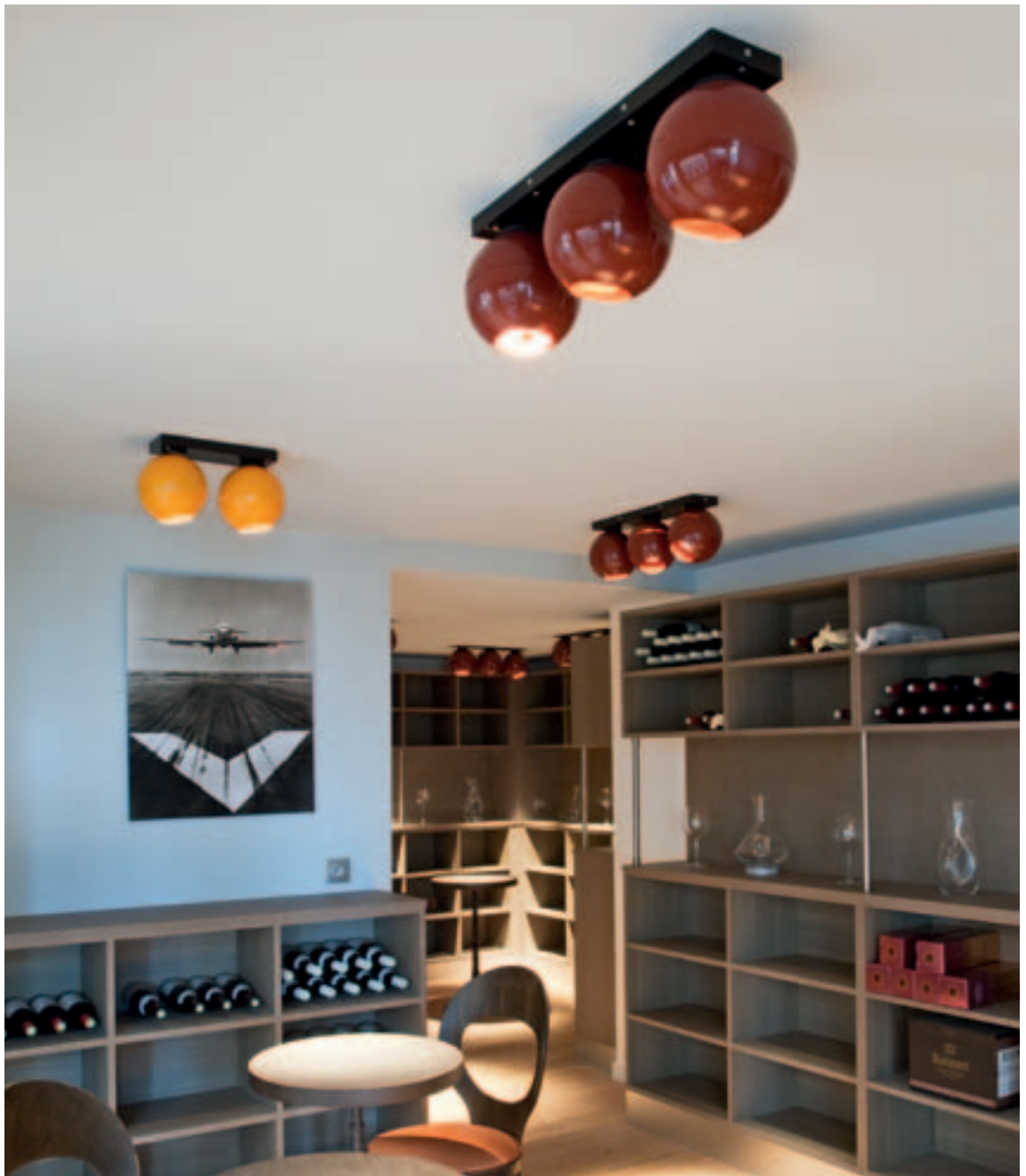

12-25 SET 3 _ 12-25 SET 2 _ CROSSLIGHT WALL

Project: l'Escale, Le Touquet

Concept et réalisation: Dogsign Architecture, Lille





12-25 set 2

Project: Private Home, Brugge
Architect: Lieven Musschoot



BRIDGE _ BRIDGE WALL

Project: Sint Jan, Marke
Architect: Redline Projects









BRIDGE

Project: Restaurant l'Ostréade, Paris
Concept: Neyvoz Architecture, Montreuil
Réalisation: IPSO, La Garenne Colombes

CROSSLIGHT

Project: Tio
Concept: Workshopofwonders



SPACEWALKER

Project: Digiking, Hasselt
Concept: Deusjevo





12-25 SET 2 _ ICE

Project: Agence de Voyage Leclerc, Arras
Architect: Daniel Copin Design, Arras

OBLIVION

Project: Restaurant Oh Poivrier, Paris
Concept: Jérémie Moller Architecture, Paris
Assistance: Conran contracts, Paris

TSJOEPY

Project: Le paradis du fruit, Paris
Architect: Opus Certum Architecture, Paris
Assistance: DEC, Paris





CANNA-2 _ 12-25 SET 3

Project: Optiek Henckaerts, Kapellen
Architect: Lieven Musschoot







ICE BM

Project: Lion Nathan, Australia
Architect: Project Control Group



d-COW

Project: Lion Nathan, Australia
Architect: Project Control Group







12-12
Project: The Foodmaker, Gent
Concept: Puresang

TSJOEPY
Project: Mr. Grill, Brugge
Architect: Expanion Team

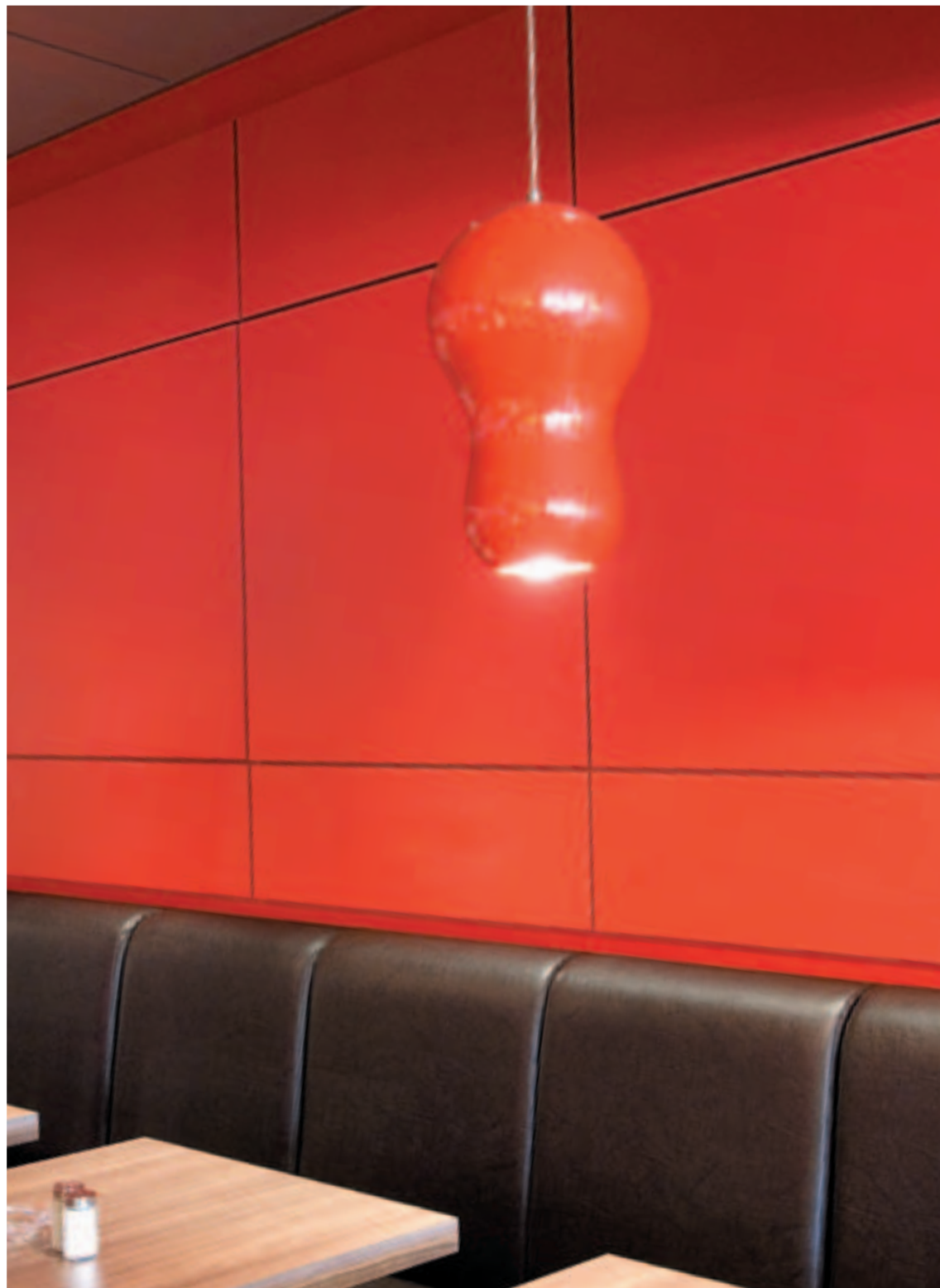

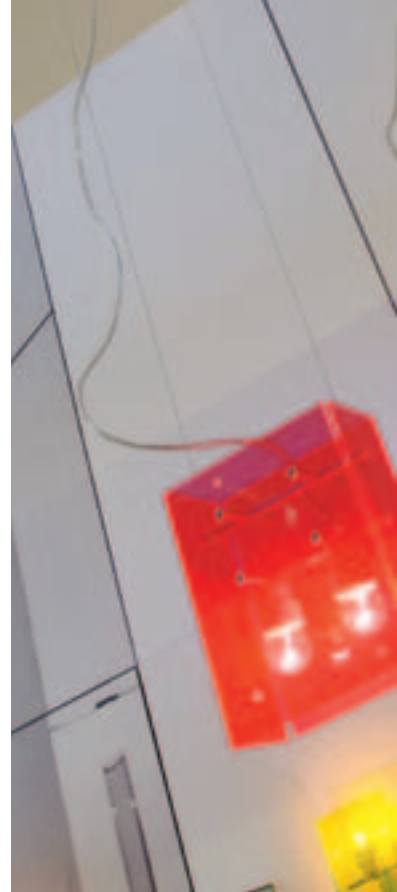



OBLIVION _ NO COPY

Project: Duravit Event, Antwerpen
Concept: Dark studio

BRIDGE

Project: Mr. Grill, Brugge
Architect: Expanion Team

BRIDGE _ BRIDGE WALL

Project: VW Shop European Motor Show, Brussel
Arch. Expanion Team

BRIDGE

Project: VW Shop European Motor Show, Brussel
Arch. Expanion Team

d-COW

Project: Adrem keukens, Eeklo

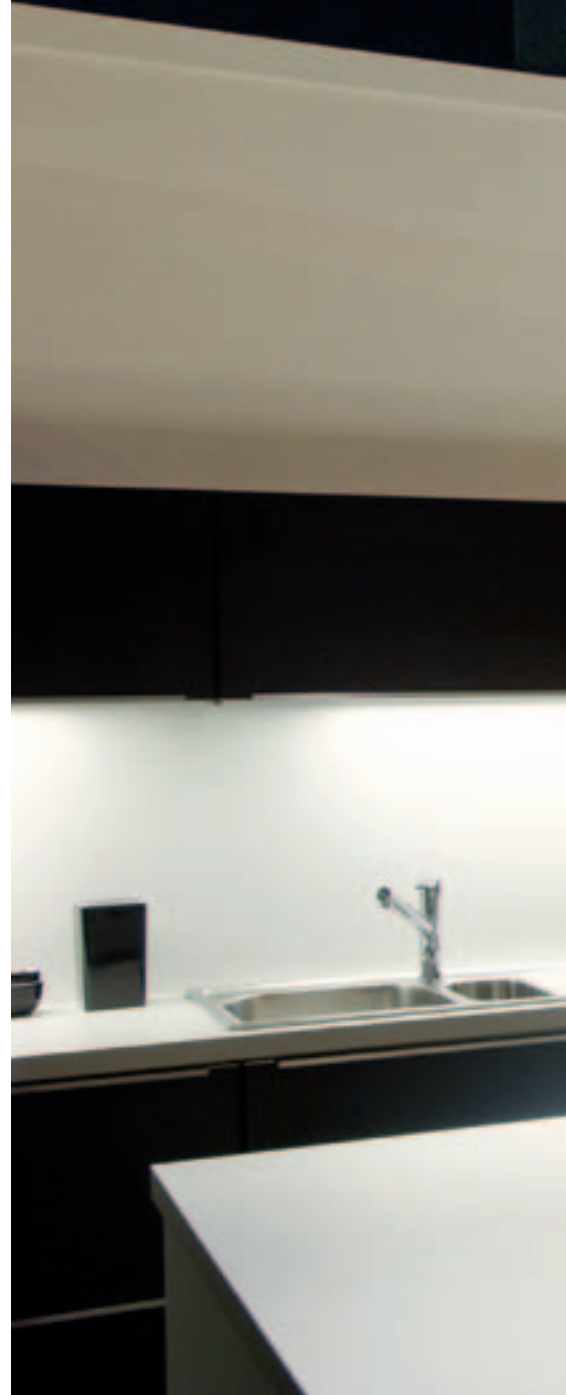





12-25 _ BRIDGE

Project: Euphony Lounge
Concept: Deusjevo







TRAPPED

Project: Punta Est, Brugge
Concept: Dark studio

HOPPY

Exterieur 2008



FRANJE TABLE

HOPPY

Sfeer 2006, Gent

ROSET

Exterieur 2008









D2V2

Project: Magasin RG-512, Ivry sur Seine
Architect: ARC & TYP Architecture, Paris
Concept: Gaël Drignon

FRANJE

Project: Showroom Oving Projectinrichting
Architect: Sanne Willemsen







T&T

Project: Bamboeddha, Kortrijk
Concept: Frederic's





HOPPY _ ICE _ POC

Project: BENT, Beveren-Lochristi-Oostende

Concept: Dark studio



SPINE

Project: Finesse, Maldegem
Concept: Dark Studio







FRANJE

Project: Square, Brussel
Concept: A&B Project



METROPOLIS

Project: Demonstrate Office spaces
Concept: Kate Stockman for Demonstrate





THE BEST ACTIVITIES
FOR YOUR HEALTH ARE
**PUMPING AND
HUMPING.**

MY CHILD



d-RABBIT

Project: Demonstrate Office spaces
Concept: Kate Stockman for Demonstrate



12-25

Project: Willemen, Mechelen
Lighting design: Ivan Missinne







d-LEATHER

Project: Headquarters Redline Projects, Roeselare
Architect: Natasia Fanariotis for Redline Projects







12-25 SET2 _ BRIDGE 3P

Project: Privat Home, Brugge

CYBE plug-in

HYPE

Project: Unic Design, Meulebeke
Architect: Beek Design

NO FRUIT

Project: Hotel Eden Roc, Cap d'Antibes, France
Lighting design: Didier Courbe







TSJOEPY

Project: Grill-Restaurant Elckerlijc, Maldegem
Concept: Dark Studio





ICE

Project: Office of architects, Norway
Interior Architect: Anne Ma Torp



CROSSLIGHT

Project: Bottarga, Oostende
Architect: Crayon projects

CYBE

Project: Orango

CROSSLIGHT

Project: Arte, Kortrijk
Architect: Steve Dumortier

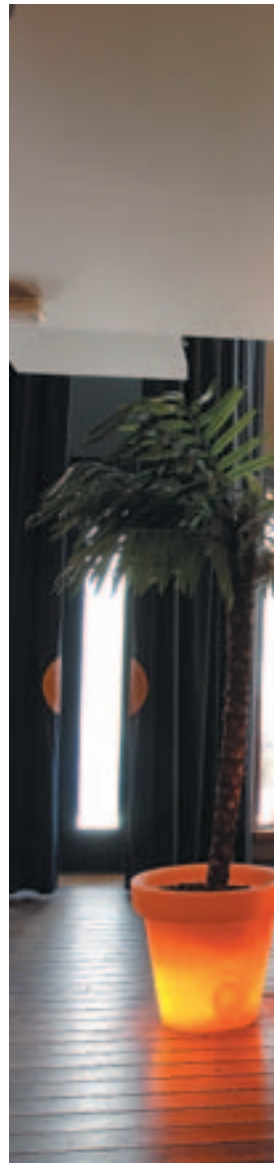



12-25

Project: Filou & co

POC_ 12-25

Project: Cassari, Mechelen

Architect: Studio Satrima

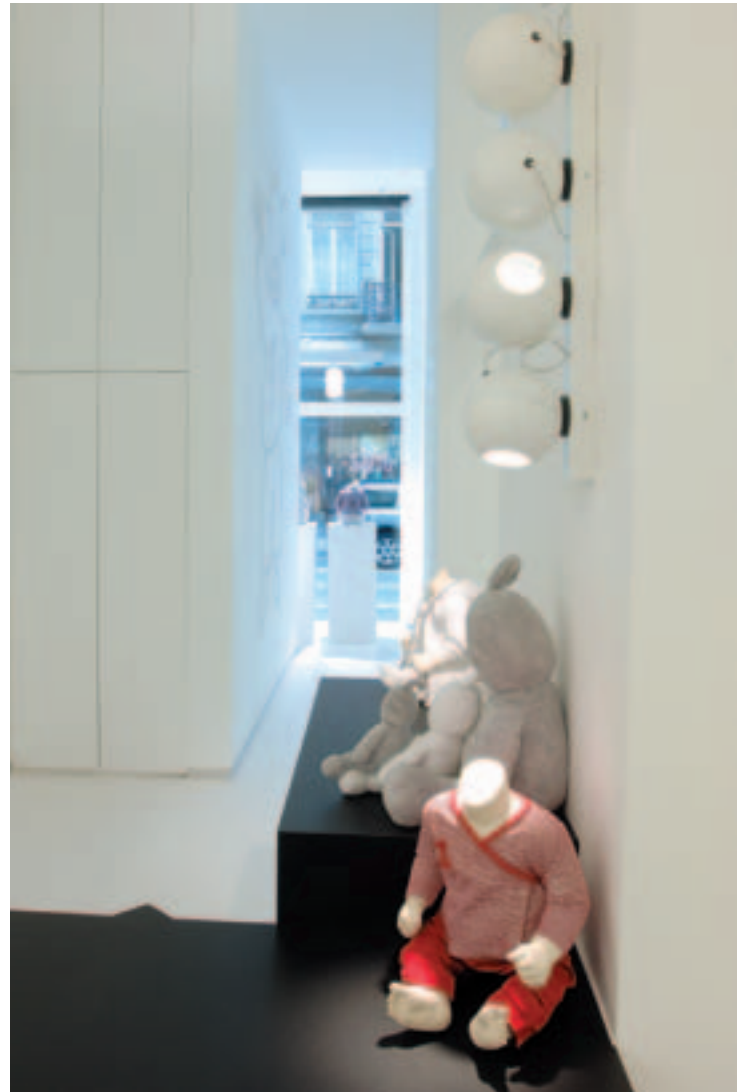

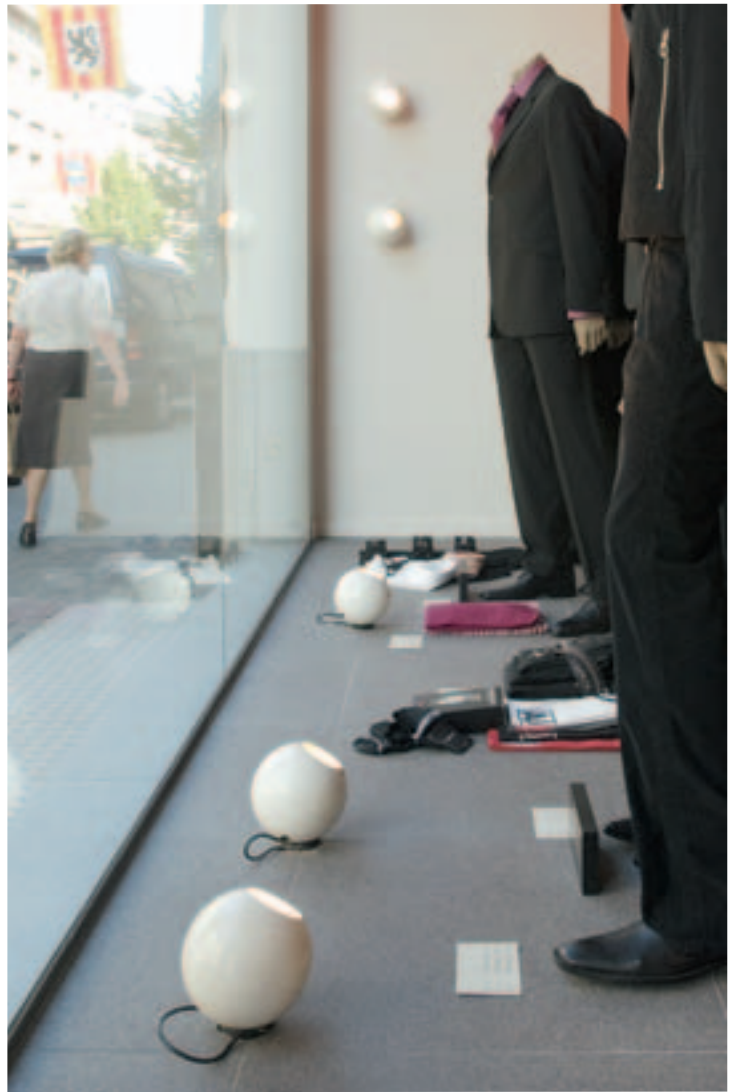



POC _ ICE _ BRIDGE

Project: BFO, Gent

Architect: Natasia Fanariotis for Redline Projects







NO FRUIT _ 12-25 _ FRANJE _ CROSSLIGHT

Project: Showroom Ahrend, Groningen
Architects: Joke Bult & Jeltje De Jong





GUM
Project: Private Home

NO FRUIT
Project: Jongform

ICE
Project: Bulthaup



HOPPY

Project: Le Soir, Brussel
Architect: Planisphère

CROSSLIGHT

Project: Unic Design, Meulebeke
Architect: Beek Design

HOPPY 3P

Project: Scheers

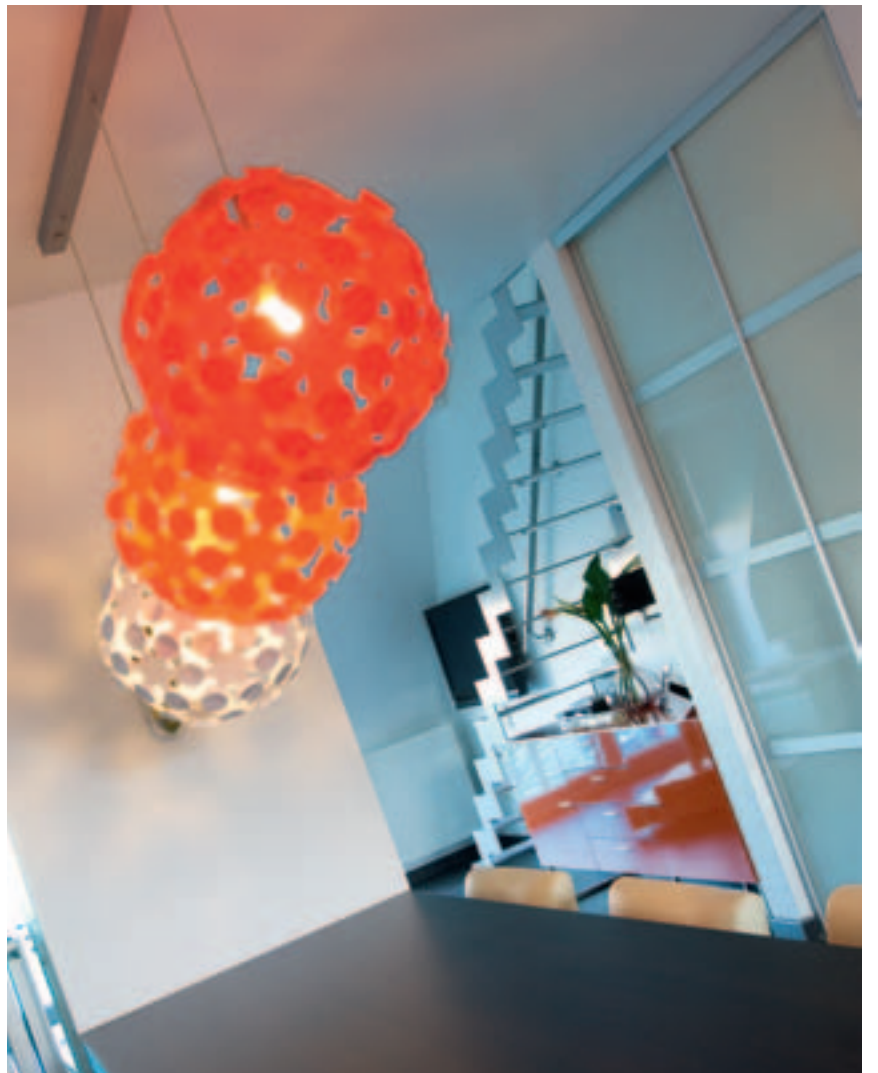



OBLIVION _ 12-25

Project: Hope hairdresser, Oslo, Norway
Architect: Element Arkitekter





**OBLIVION**

Project: Showroom Ahrend, Groningen
Architects: Joke Bult & Jeltje De Jong

PAWWW

Project: Restaurant l'Escale, Le Touquet
Concept et réalisation: Dogsign Architecture, Lille

TSJOEPY S

Project: Hotel Mercure, Nieuwegein

Architect: Etienne Bouten for B+B interieurarchitectuur

TSJOEPY R_ TSJOEPY S

Project: CKS, Knokke

Architect: Co Twee

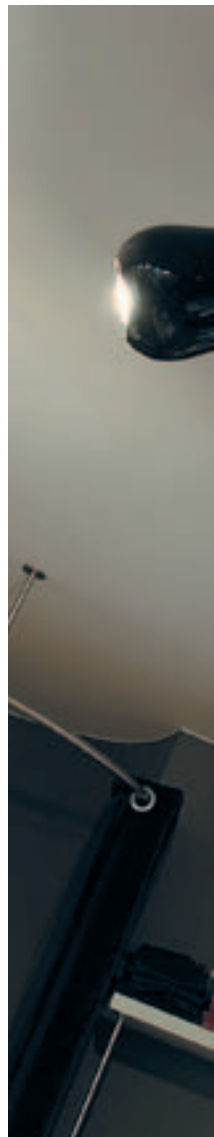

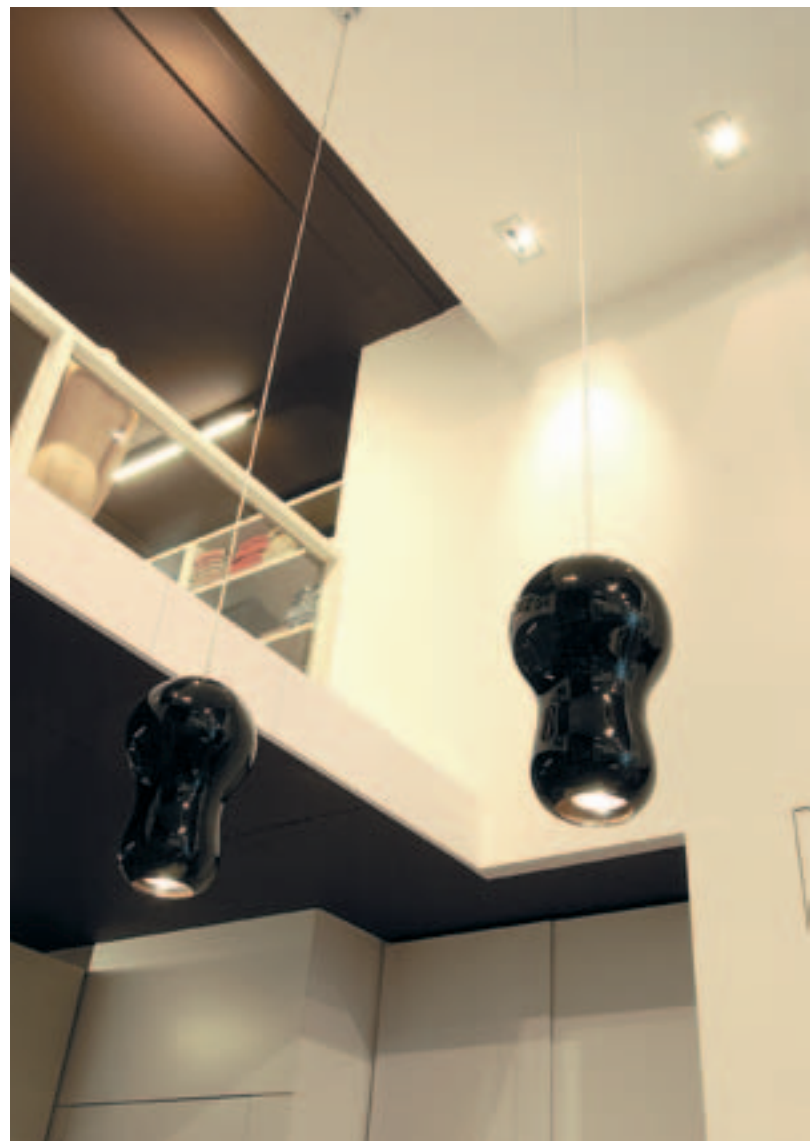



SON OF EDDY _ 12-25

Project: Horebeekse boekhandel

Architect: Patrick Matthys

CROSSLIGHT

Project en Concept:

Confetti reclamefabriek, Rotterdam





CHUBBY BOX _ R&S

Project: Q-Music Beach House
Concept: Dark studio



d-CONCRETE

Project: Loft, Gent

Architect: Ivan Missinne

JUICE

Project: CKS, Knokke

Architect: Co Twee

POC

Project: Zole Male, Rotterdam

Architect: Caroline Langemeyer

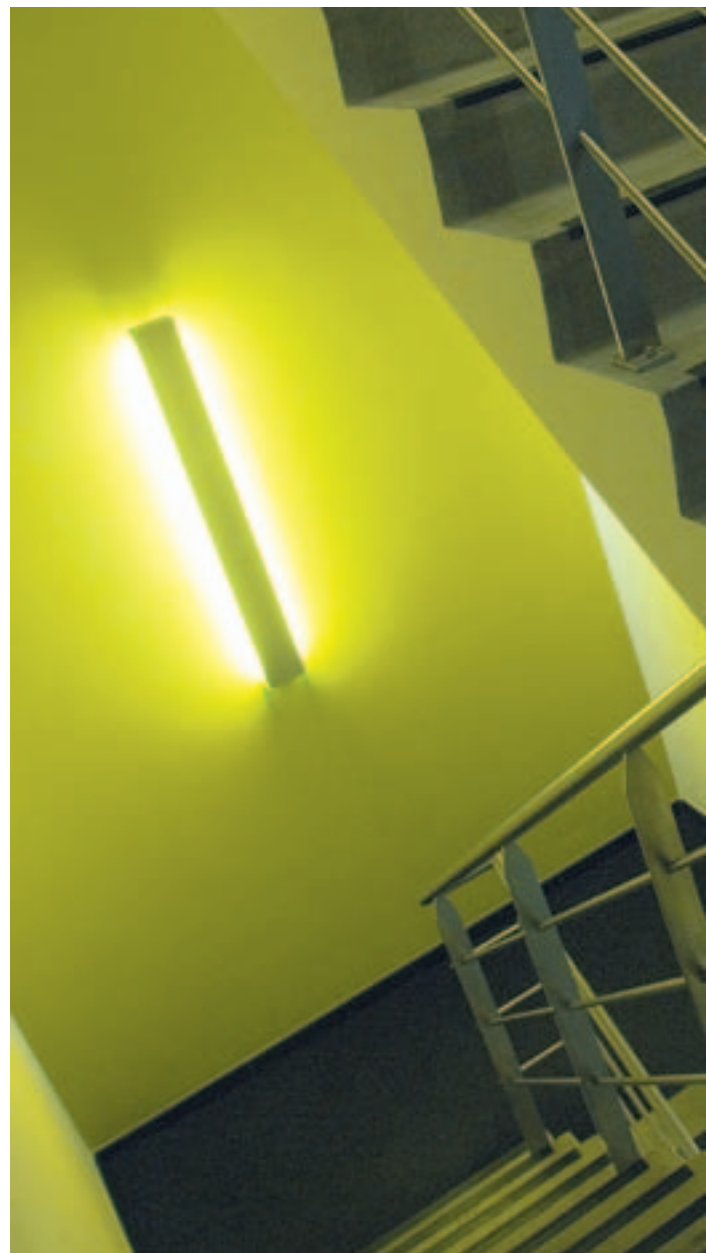



d-SQUEEZE

Project: Habbekrats

NO FRUIT

Project: Townhall, Deerlijk

Architect: Nero

NO FRUIT

NO FRUIT bling bling

Interieur 2006





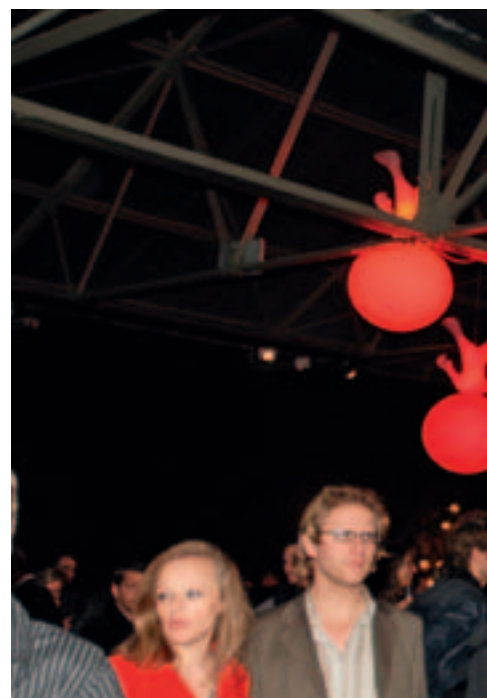



NO FRUIT

Project: Tao, Oostende
Architect: Crayon Projects

CROSSLIGHT WALL

D2V2
International Movie Festival Gent

SPACEWALKER

Exterieur 2008

BRIDGE

Project: Chilli Jam

HYPE

Project: Beauty Nail Center, Sint-Niklaas

Concept: Equipal

LA CAGE

Project: Demonstrate Office spaces

Concept: Kate Stockman for Demonstrate





NO FRUIT bling bling _ 12-25

Project: Loft, Oudenaarde
Architect: Patrick Matthys







OBLIVION _ TWOLVE

Exterieur 2008

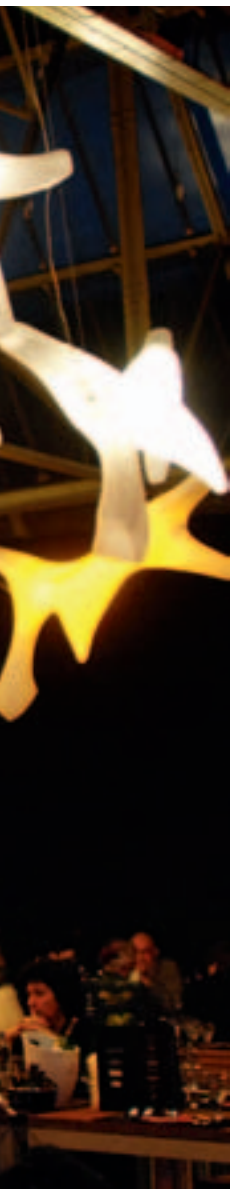

TSJOEPY _ 12-25 _ NO FRUIT

Project: Priva Campus, Rotterdam
Architect: Confetti reclamefabriek







TWOLVE

Project: Cnockaert, Oudenaarde
Architect: Patrick Matthys





BRIDGE

Project: WTC, Amsterdam
Concept: Illum kunstlicht



BRIDGE
Project: Kitchen, Luik
Architect: Valentini



ICE

Project: Videohouse, Vilvoorde
Concept: Dark studio





d-RABBIT _ FRANJE

Project: Showroom Torino

PAROQ 3 _ GUM 01 _ CHESTER S

Project: Restaurant De Croone, Ninove

Concept: Lichtadvies Ninove





PANTY _ BRIDGE _ 12-25

Project: Hotel Orchidee, Aalter
Concept: Dark studio





OBLIVION _ BRIDGE

Project: The Zone, Gent

Architect: Natasia Fanariotis for Redline Projects

CYBE

Project: Tantra, Gent



D2V2

Project: Longin services

Architect: Studio Satrima

HEAPS

Showroom, Roeselare

NO COPY

Project: OCMW, Maldegem

Architect: Aiko

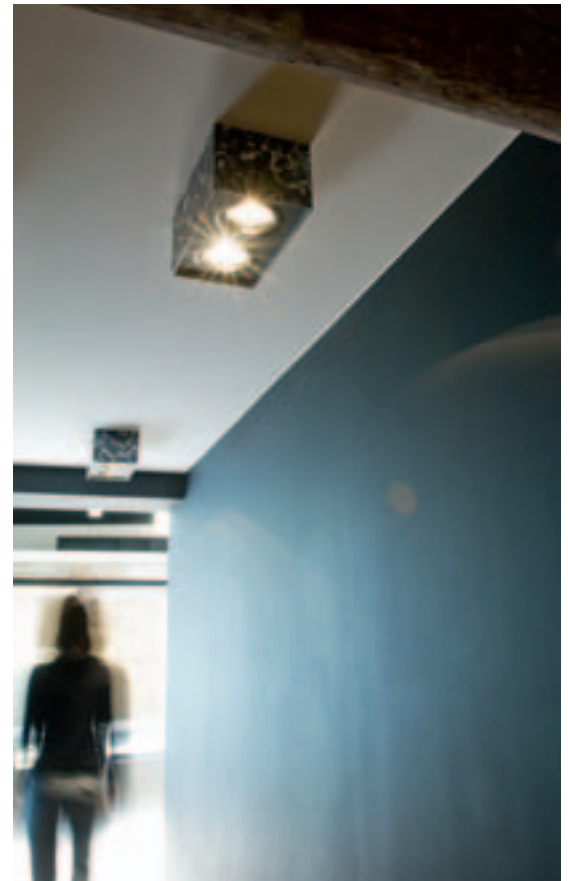





HOPPY

Project: Fresh Food Distribution Braet
Concept: Integral Eeklo

12-25

Project: Restaurant Oud Sluis, Sluis
Architect: Lieven Musschoot

D2V2

Project: Golf Zone, Linz
Architect: Epps



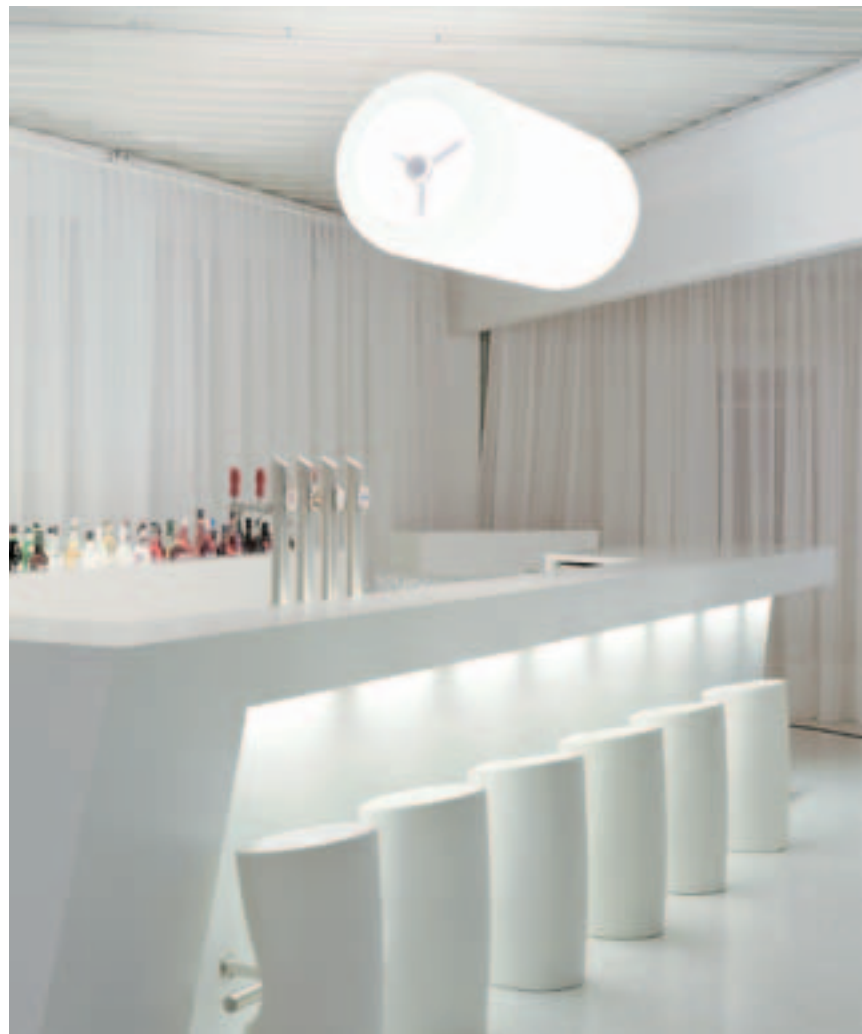

d-SQUEEZE _ BRIDGE

Meeting Point KP2, Kortrijk

NO FRUIT _ BRIDGE

Project: Macchiato, Hasselt

Concept: Puresang









HOPPY _ 12-25 _ CROSSLIGHT _ NO COPY _ SON OF EDDY

Project: Belgium-EU Pavilion, World Expo 2010, Shanghai
Architect: Conix | Architects







POC

Project: Van Rietschoten Design, Amersfoort
Concept: Martin Van Rietschoten

POC

Project: Showroom Ahrend, Groningen
Architect: Joke Bult en Jeltje De Jong



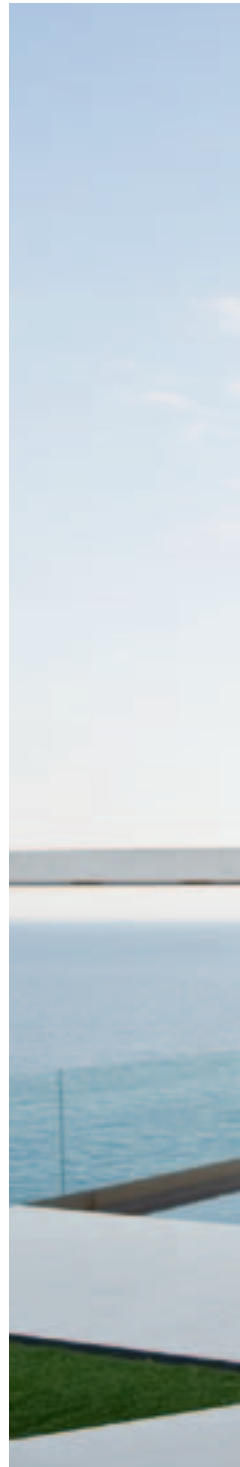

BRIDGE

Project: Private Home, Barcelona
Architects: Soler-Morato





D2V2 _ 12-25
Project: Cocoon, Lambersart



CROSSLIGHT

NO COPY

NO COPY _ METROPOLIS

Project: Dodds, Knokke

Concept: Dark studio







12-25 _ CROSSLIGHT

Project: De Brooderie, Diksmuide
Concept: Dark studio





SQUARE ANGEL

Project: Galerie St-Hubert
Concept: Luc Vincent





BRIDGE _ FRANJE _ CYBE

Project: Priva Campus, Rotterdam
Architect: Confetti reclamefabriek



PAROQ 3

Project: Lingerie Marie-Paule, Wetteren
Concept: Lightlab





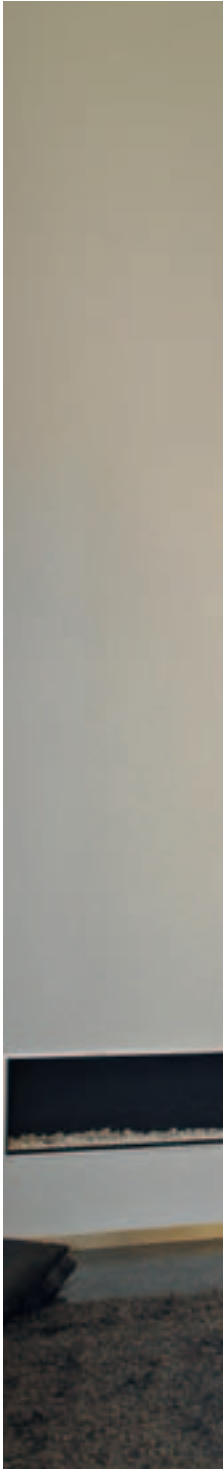

**OBLIVION**

Project: Pami, Brussel
Architect: Wim Vos

TWOLVE

Project: Dilanno, Sint Martens Latem



**CHUBBY**

Project: Dodds, Knokke

FRANJE _ POC

Project: La Perla, Brussel
Concept: Dark studio



FRANJE

Project: Dudok, Arnhem

GUM

Project: Sweet coffee, Beveren

Architect: Lieven Musschoot







NO FRUIT _ TRAPPED

Project: Tao, Oostende
Architect: Crayon Projects





SPACEWALKER _ T&T _ PAWWW _ TWOLVE
Reddot Design Museum, Singapore

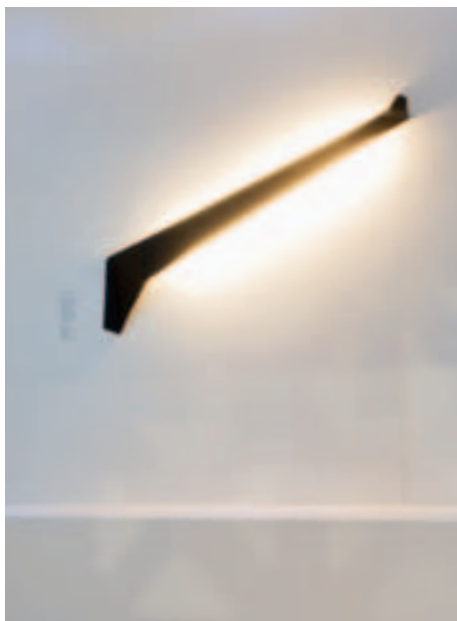

ICE _ JUICE

Project: Willemen, Mechelen
Lighting design: Ivan Missinne







METROPOLIS

Project: Axxent

CROSSLIGHT

Project: Dienst Ruimtelijke orde en Economische zaken, Groningen
Architect: Nicole Lagarde for De Zwarte Hond

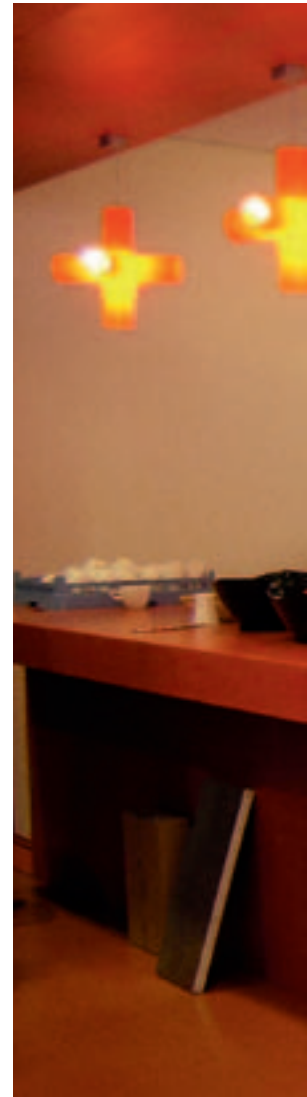





D2V2 _ NO FRUIT

Project: Kinopolis, Luik
Architect: Es°te group

SPACEWALKER

Exterieur 2008



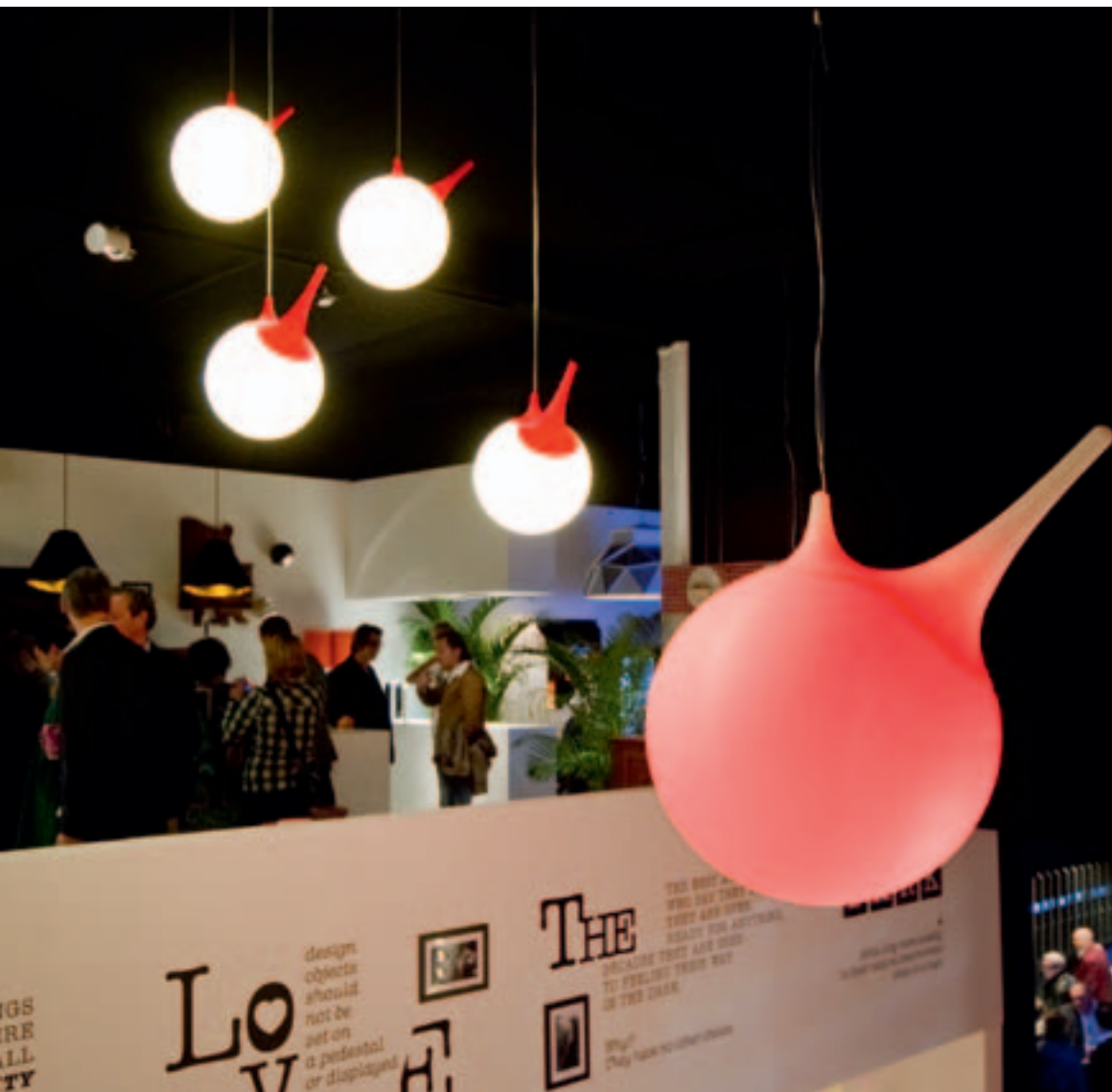



**NO COPY _ SNOWDOME**

Project: Acta, Bommel
Concept: IngeClaudia

CYBE MAX

Project: Scheelinck

SNOWDOME

Project: Hotel Orchidee, Aalter

TSJOEPY

Project: Mr. Grill, Brugge
Architect: Expansion Team

D2V2 _ BRIDGE

Project: Mr. Grill, Brugge
Architect: Expansion Team







ICE

Project: Wim Motors, Lotenhulle
Concept: Dark studio

TSJOEPY

Project: Bultaup

NO FRUIT

Project: Regis Zen Building, Utrecht
Lighting designer: Nadja Smits

TRAPPED

Project: Belastingdienst, Eindhoven
Architects: Jos Brouwers & Minka Weeda

CROSSLIGHT _ HOPPY

Project: Cannockchase, Den Haag
Interior design: Boo





POC _ d-CONCRETE _ D2V2 FLOOR _ ICE

Project: Espace Concept, GHLuxembourg





© Copyright Dark®

Dark has the right to change any technical data, dimensions, colours and characteristics without prior notice. - All rights reserved.

Any reproduction of the Dark products is strictly forbidden and can seriously damage your health and endanger your bank account.

CONCEPT & GRAPHIC DESIGN

Headline

PHOTOGRAPHY

Kris Dekeijser

Wolf+Dort

Verne

Ben Urbain

Marco Mertens

Jorge Ovaa

Hans Morren

Jons Jeronimus

Koen Van Damme

WITH THE SUPPORT OF

Flanders Investment & Trade

Government of Flanders - Belgium

HEAD OFFICE:

DARK nv
Beversesteenweg 565
8800 Roeselare – Belgium
Phone +32 51 25 25 55
Fax +32 51 25 25 56
info@dark.be
www.dark.be

DARK WORLDWIDE:

THE NETHERLANDS
Illum
Waaier 50
2451 VW Leimuiden – Nederland
Phone +31 172 506 668
Fax +31 172 506 669
info@illum.nl

UK
13-16 Britton Street
Farringdon
London EC1M 5SX - United Kingdom
Phone +44 20 7253 0402
Fax +44 20 7253 0404
Phone 00800 36 25 36 25 (toll free nr)
Fax 00800 45 60 78 90
uk@dark.eu

ITALY
Via Isonzo 96
10141 Torino – Italia
Phone +39 011 38 35 177
Fax +39 011 38 35 172
italy@dark.eu

GERMANY
Schanzenstrasse 39 D17
51063 Köln – Deutschland
Phone +49 221 96447510
Fax +49 221 96447515
Phone 00800 36 25 36 25 (toll free nr)
Fax 00800 45 60 78 90
germany@dark.eu

IBERIA
Latinoamérica – Angola
C/Emilio Rubín 11
28033 Madrid – España
Phone +34 913 005 470
Fax +34 913 004 730
spain@dark.eu

ASIA PACIFIC LTD.
RM. 1413, Block A, Sea View Estate
2 Watson Road
North Point – Hong Kong
Phone +852 2110 6955
Fax +852 3106 4096
asia@dark.eu



Member of the 2B Delighted® group  **delighted**